

A6SF F1

A6 Welding head SAW, Single

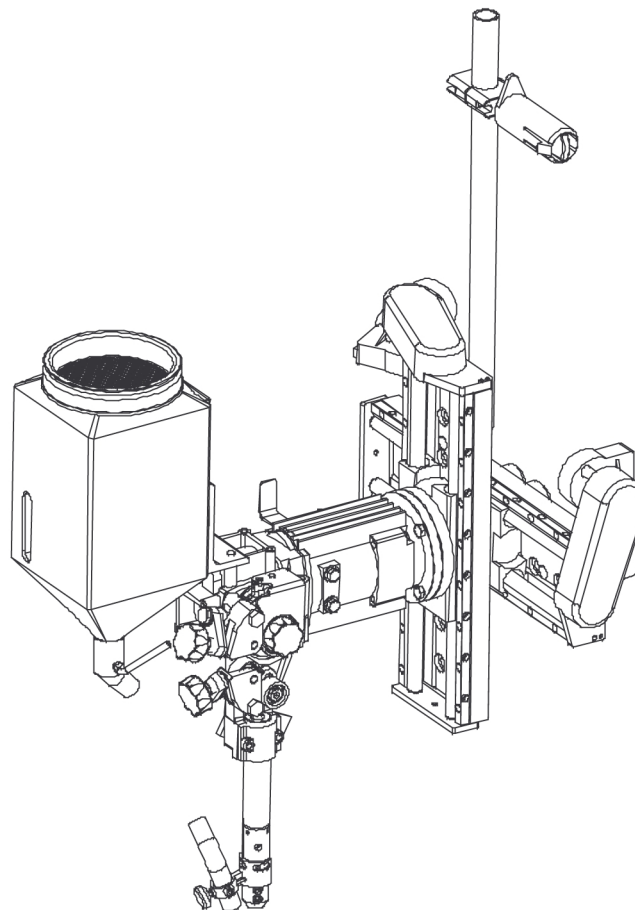

Spare parts list

Ordering no.	Product	Notes	Serial no.
0449 270 900	A6 SF F1	SAW (156:1), manual slide, PEK	
0449 270 901	A6 SF F1	SAW (156:1), motorised slide, PEK and A6 PAV	
0449 270 902	A6 SF F1	SAW (156:1), motorised slide, PEK and A6 GMH	
0449 270 903	A6 SF F1	SAW (156:1), motorised slide	
0449 270 904	A6 SF F1	SAW (156:1), motorised slide, PEK and A6 PAV	
0449 270 905	A6 SF F1	SAW (156:1), motorised slide, PEK and A6 GMH	
0449 270 906	A6 SF F1	SAW (156:1), motorised slide, PEK	
0449 270 910	A6 SF F1	SAW (74:1), manual slide, PEK	
0449 270 911	A6 SF F1	SAW (74:1), motorised slide, PEK and A6 PAV	
0449 270 912	A6 SF F1	SAW (74:1), motorised slide, PEK and A6 GMH	
0449 270 913	A6 SF F1	SAW (74:1), motorised slide, PEK	
0449 270 914	A6 SF F1	SAW (74:1), motorised slide, PEK and A6 PAV	
0449 270 915	A6 SF F1	SAW (74:1), motorised slide, PEK and A6 GMH	
0449 270 916	A6 SF F1	SAW (156:1), motorised slide, PEK	
0449 270 950	A6 SF F1	SAW (115:1), motorised slide	

Spare parts may be ordered through your nearest ESAB dealer, see esab.com. When ordering, please state product type, serial number, denominations and ordering numbers according to the spare parts list. This facilitates dispatch and ensures correct delivery.

Maintenance and repair work should be performed by an experienced person, and electrical work only by a trained electrician. Use only recommended spare parts.

1	SPARE PARTS	4
1.1	Welding head with PEK.....	4
1.2	Welding head with PAV and PEK	5
1.3	Welding head with GMH and PEK.....	6
1.4	Welding head with PEK.....	7
1.5	Welding head with PAV and PEK	8
1.6	Welding head with GMH and PEK.....	9
1.7	Welding head with PEK.....	10
1.8	Welding head with PEK.....	10
1.9	Welding head with PAV and PEK	11
1.10	Welding head with GMH and PEK.....	12
1.11	Welding head with PEK.....	13
1.12	Welding head with PAV and PEK	14
1.13	Welding head with GMH and PEK.....	15
1.14	Welding head with PEK.....	17
1.15	Welding head without control unit.....	17
1.16	Wire feed unit (Right mounted).....	18
1.17	Wire feed unit.....	19
1.18	Wire feed unit.....	20
1.19	Wire feed unit (Right mounted).....	21
1.20	Wire feed unit (Right mounted).....	22
1.21	Wire straightener (right mounted)	23
1.22	Contact equipment single wire	25
1.23	Contact equipment single wire	25
1.24	Contact jaw tube.....	26
1.25	Flux nozzle complete	27
1.26	Flux hopper.....	28
1.27	Flux hopper.....	29
1.28	Flux valve	30
1.29	Guide tube insert for fine wire.....	31
1.30	Slide travel kit motorised.....	32
1.31	Slide travel kit, manual	33
1.32	Slide, manually operated	34
1.33	Bobbin holder complete	35
1.34	Bobbin holder complete	36

1 SPARE PARTS

1.1 Welding head with PEK

Item no.	Qty	Ordering number	Denomination	Notes
		0449 270 900	Welding head with PEK	A6SF F1, SAW (156:1)
1	1	0449 250 880	Wire feed unit (right mounted)	156:1
2	1	0449 252 881	Slide travel kit, manual	210 mm
3	1	0449 255 881	Bobbin holder complete	
3:2	1	0146 967 880	Brake hub	
6	1	0449 253 902	Cable set	L=5 m
6:2	1	0460 907 881	Motor cable	5 m
6:3	1	0461 239 884	Arc welding cable	5 m
20	1	0460 504 880	Control box	PEK, see separate manual

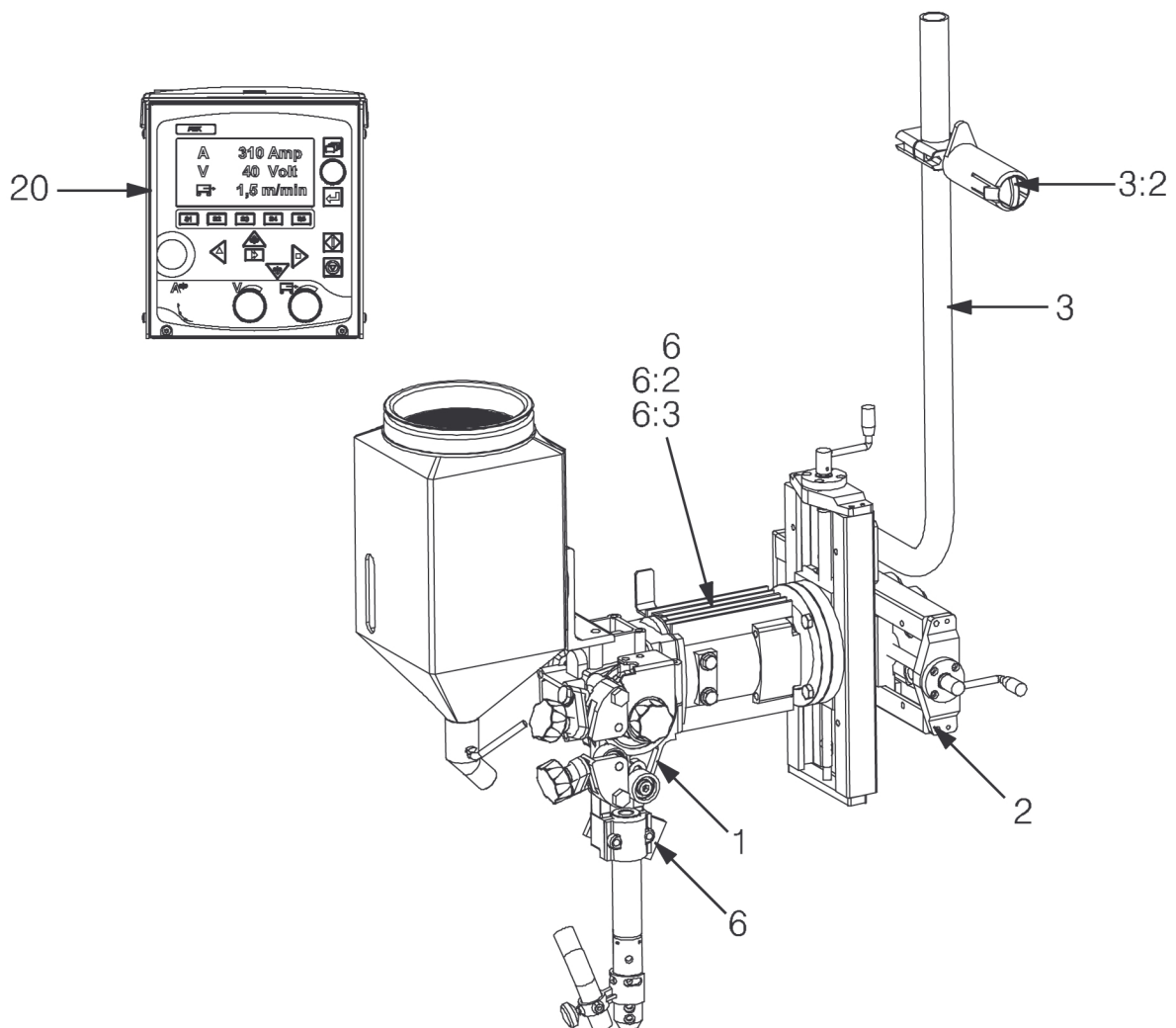

1.2 Welding head with PAV and PEK

Item no.	Qty	Ordering number	Denomination	Notes
		0449 270 901	Welding head with PAV and PEK	A6SF F1, SAW (156:1)
1	1	0449 250 880	Wire feed unit (right mounted)	156:1
2	1	0449 251 884	Slide travel kit, motorised	300 mm
3	1	0449 255 880	Bobbin holder complete	
3:2	1	0146 967 880	Brake hub	
6	1	0449 253 902	Cable set	L=5 m
6:2	1	0460 907 881	Motor cable	5 m
6:3	1	0461 239 884	Arc welding cable	5 m
20	1	0460 504 880	Control box	PEK, see separate manual
25	1	0460 697 880	Joint tracking unit	A6 PAV, see separate manual
26	1	0461 215 880	Cable set	
26:5	2	0417 310 888	Motor cable	5 m

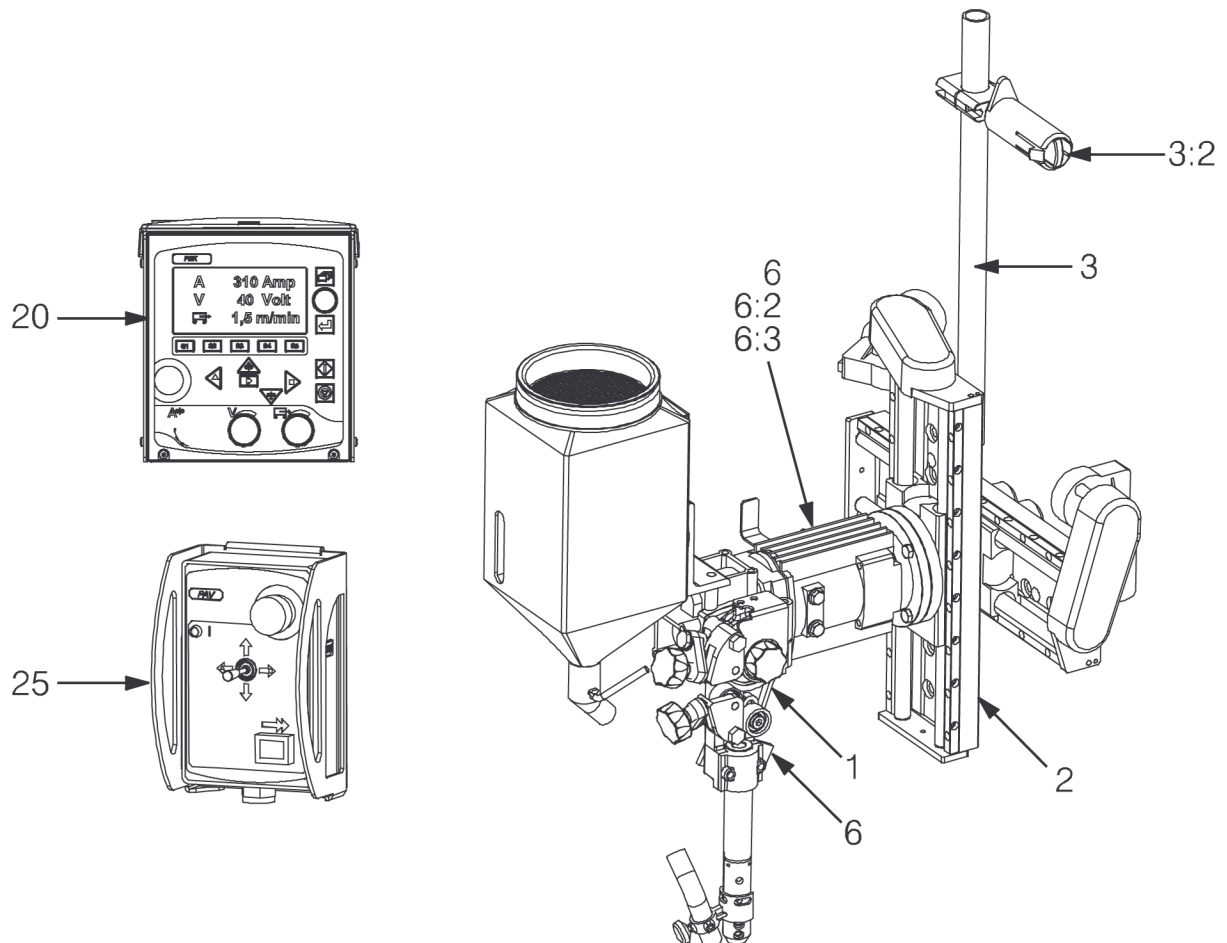

1.3 Welding head with GMH and PEK

Item no.	Qty	Ordering number	Denomination	Notes
		0449 270 902	Welding head with GMH and PEK	A6SF F1, SAW (156:1)
1	1	0449 250 880	Wire feed unit (right mounted)	156:1
2	1	0449 251 884	Slide travel kit, motorised	300 mm
3	1	0449 255 880	Bobbin holder complete	
3:2	1	0146 967 880	Brake hub	
6	1	0449 253 902	Cable set	L=5 m
6:2	1	0460 907 881	Motor cable	5 m
6:3	1	0461 239 884	Arc welding cable	5 m
20	1	0460 504 880	Control box	PEK, see separate manual
25	1	0460 884 880	Joint tracking system	A6 GMH, see separate manual
26	1	0461 215 880	Cable set	
26:5	2	0417 310 888	Motor cable	5 m

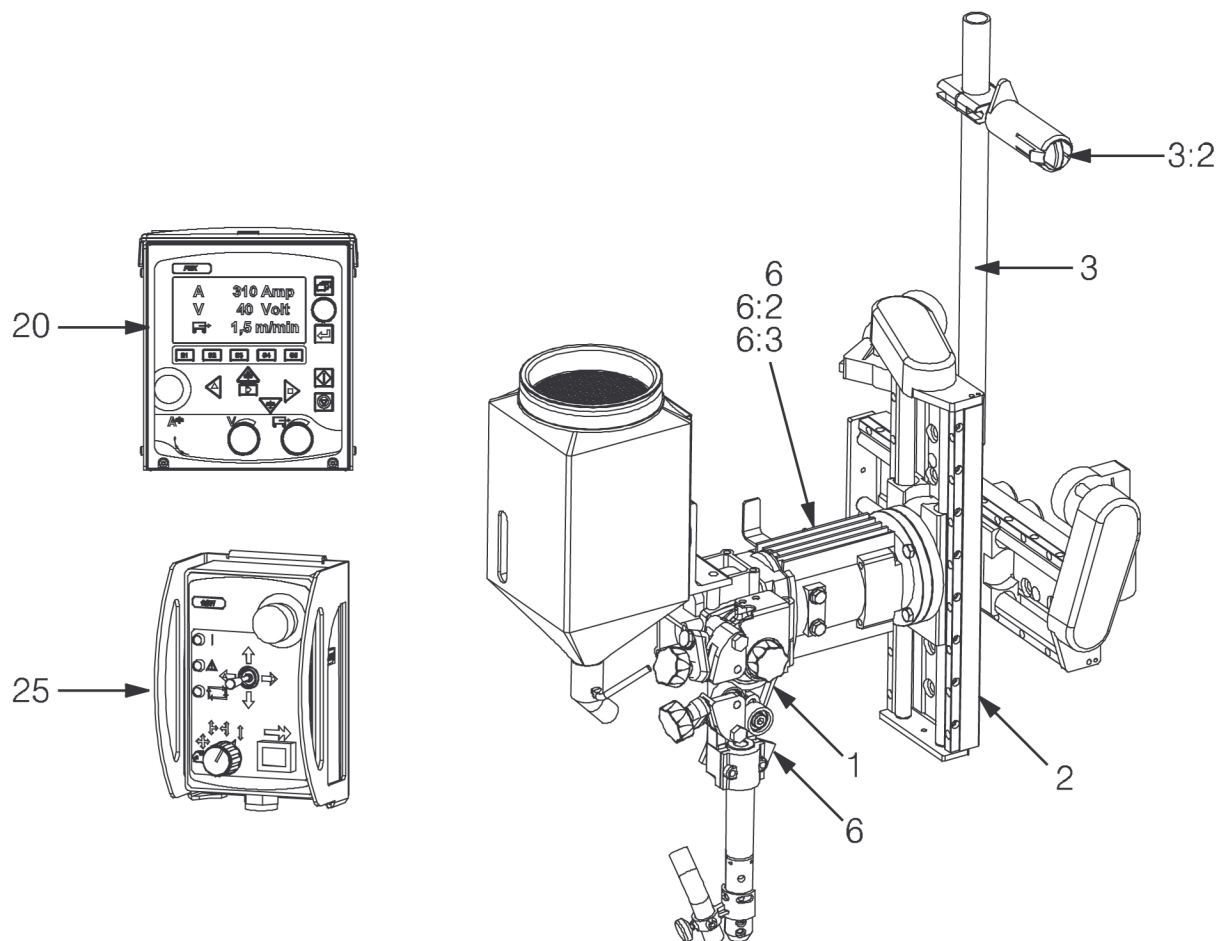

1.4 Welding head with PEK

Item no.	Qty	Ordering number	Denomination	Notes
		0449 270 903	Welding head with PEK	A6SF F1, SAW (156:1)
1	1	0449 250 880	Wire feed unit (right mounted)	156:1
2	1	0449 251 884	Slide travel kit, motorised	300 mm
3	1	0449 255 880	Bobbin holder complete	
3:2	1	0146 967 880	Brake hub	
6	1	0449 253 902	Cable set	L=5 m
6:2	1	0460 907 881	Motor cable	5 m
6:3	1	0461 239 884	Arc welding cable	5 m
20	1	0460 504 880	Control box	PEK, see separate manual

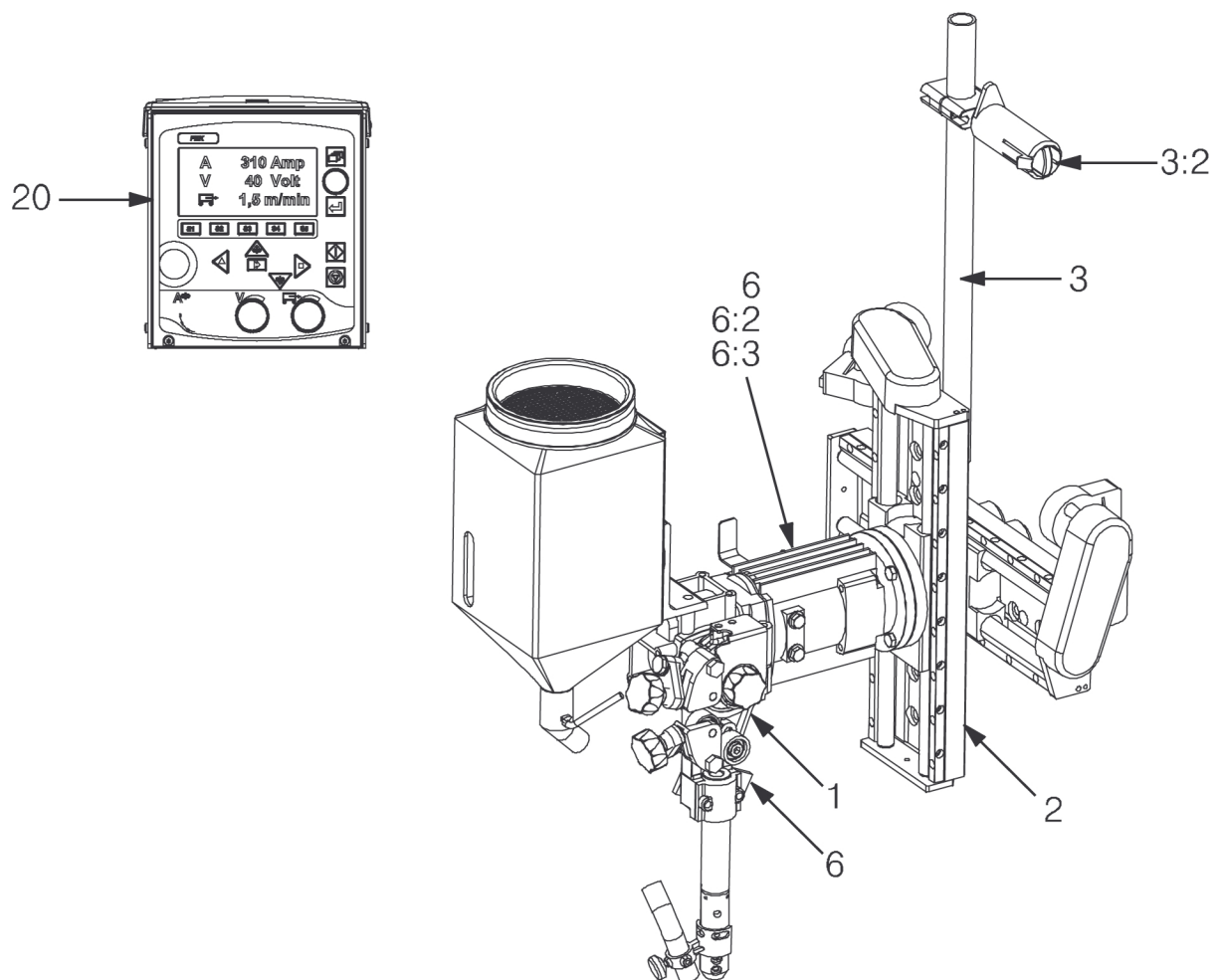

1.5 Welding head with PAV and PEK

Item no.	Qty	Ordering number	Denomination	Notes
		0449 270 904	Welding head with PAV and PEK	A6SF F1, SAW (156:1)
1	1	0449 250 882	Wire feed unit	156:1
2	1	0449 251 885	Slide travel kit, motorised	300 mm
6	1	0449 253 902	Cable set	5 m
6:2	1	0460 907 881	Motor cable	5 m
6:3	1	0461 239 884	Arc welding cable	5 m
20	1	0460 504 880	Control box	PEK, see separate manual
25	1	0460 697 880	Joint tracking unit	A6 PAV, see separate manual
26	1	0461 215 880	Cable set	

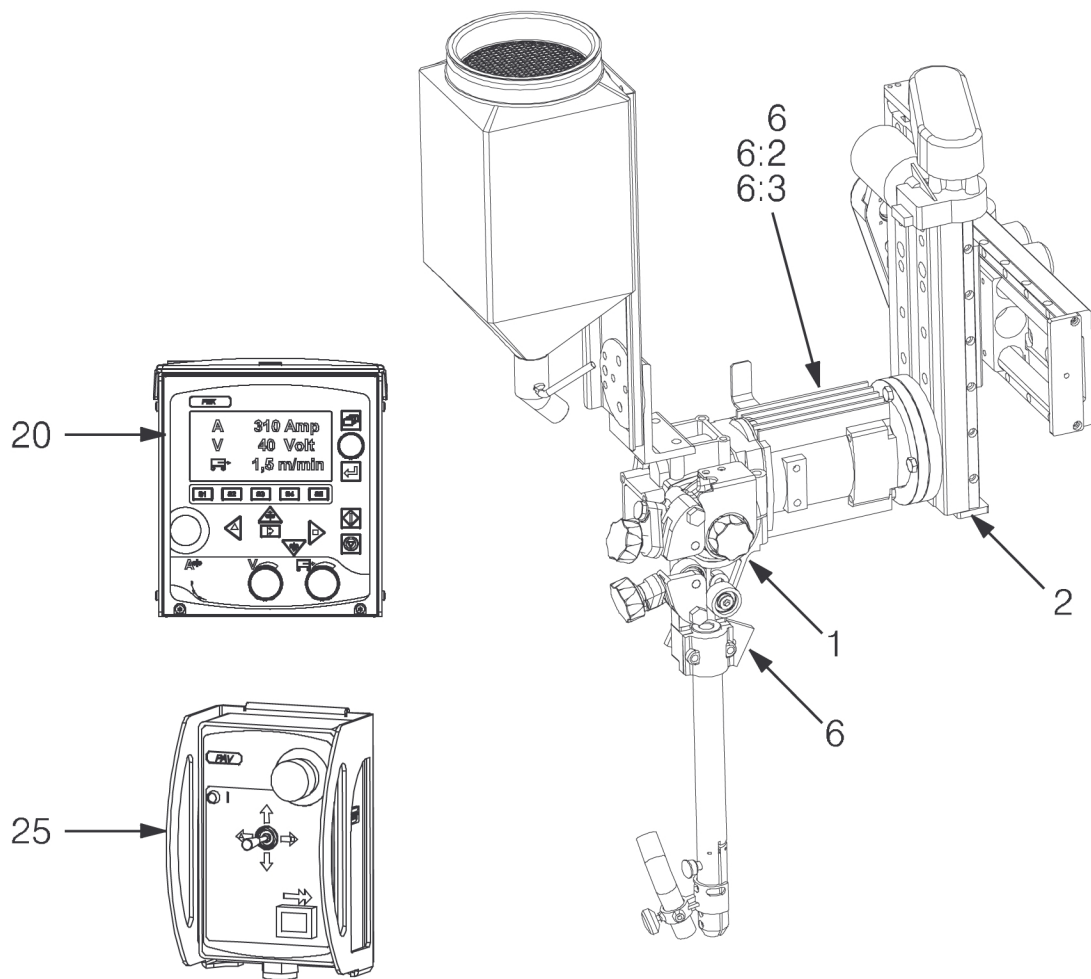

1.6 Welding head with GMH and PEK

Item no.	Qty	Ordering number	Denomination	Notes
		0449 270 905	Welding head with GMH and PEK	A6SF F1, SAW (156:1)
1	1	0449 250 882	Wire feed unit	156:1
2	1	0449 251 885	Slide travel kit, motorised	300 mm
6	1	0449 253 902	Cable set	5 m
6:2	1	0460 907 881	Motor cable	5 m
6:3	1	0461 239 884	Arc welding cable	5 m
20	1	0460 504 880	Control box	PEK, see separate manual
25	1	0460 884 880	Joint tracking unit	A6 GMH, see separate manual
26	1	0461 215 880	Cable set	

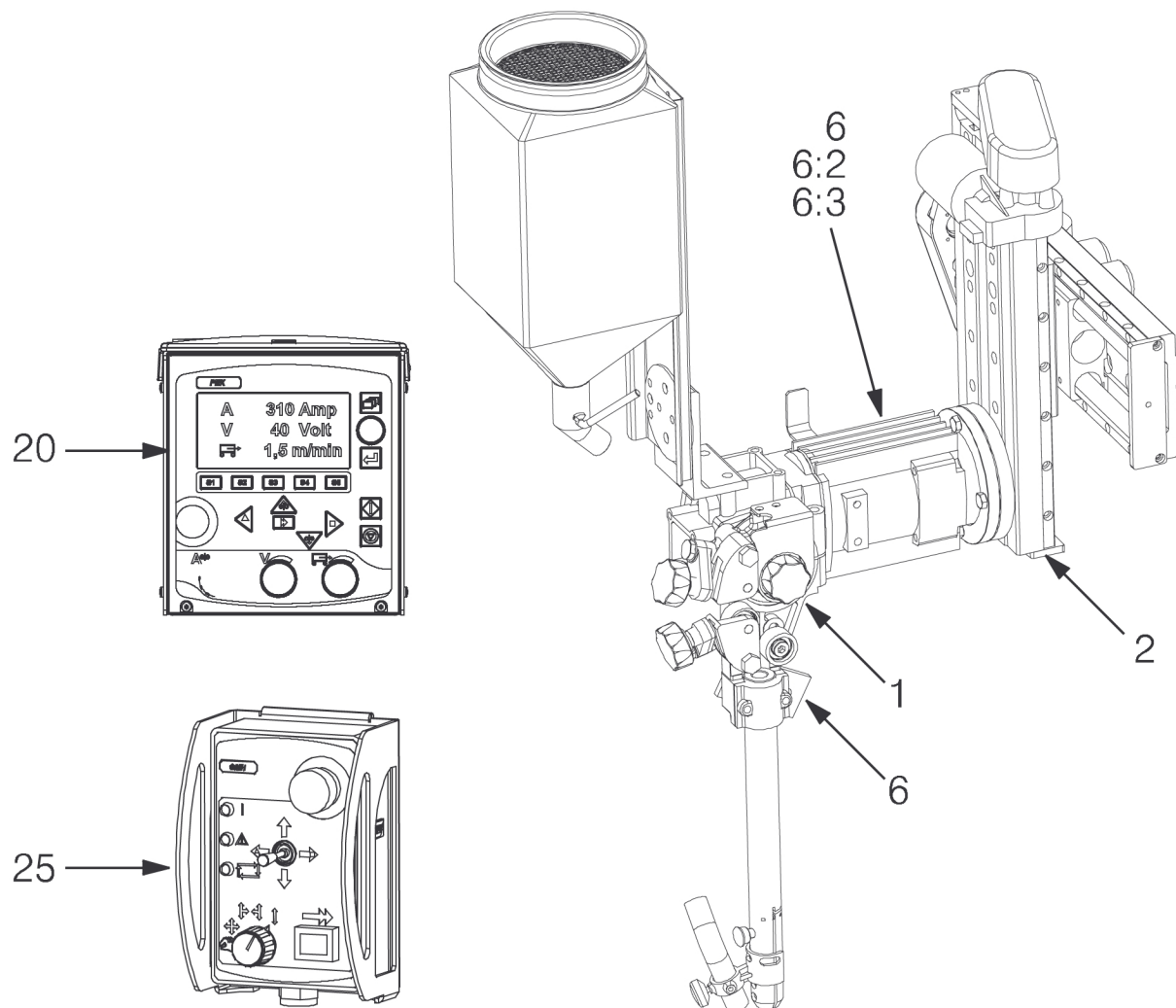

1.7 Welding head with PEK

Item no.	Qty	Ordering number	Denomination	Notes
		0449 270 906	Welding head with PEK	A6SF F1, SAW (156:1)
1	1	0449 250 882	Wire feed unit	156:1
2	1	0449 251 885	Slide travel kit, motorised	300 mm
6	1	0449 253 902	Cable set	5 m
6:2	1	0460 907 881	Motor cable	5 m
6:3	1	0461 239 884	Arc welding cable	5 m
20	1	0460 504 880	Control box	PEK, see separate manual

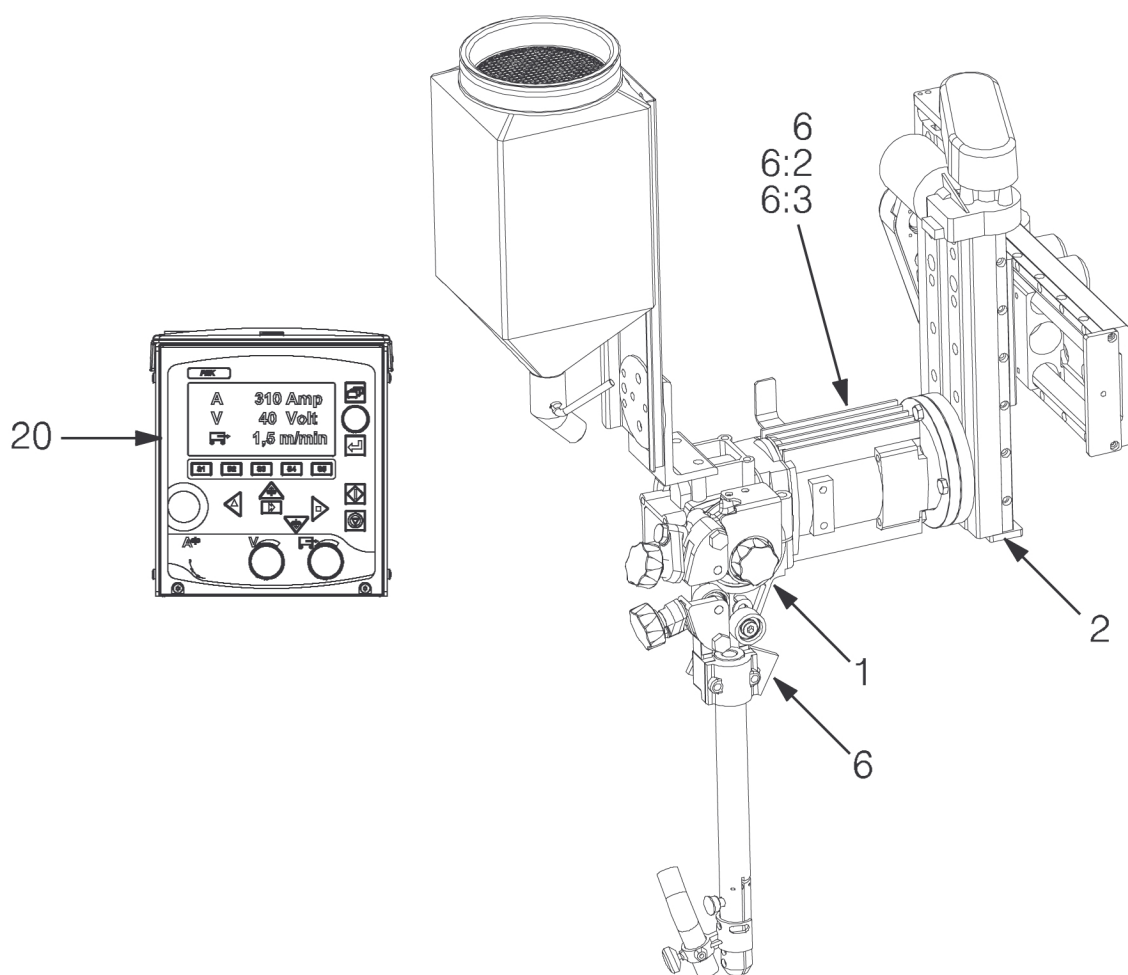

1.8 Welding head with PEK

Item no.	Qty	Ordering number	Denomination	Notes
		0449 270 910	Welding head with PEK	A6SF F1, SAW (74:1)
1	1	0449 250 890	Wire feed unit (right mounted)	74:1
2	1	0449 252 881	Slide travel kit, manual	210 mm
3	1	0449 255 881	Bobbin holder complete	

1 SPARE PARTS

Item no.	Qty	Ordering number	Denomination	Notes
3:2	1	0146 967 880	Brake hub	
6	1	0449 253 902	Cable set	L=5 m
6:2	1	0460 907 881	Motor cable	5 m
6:3	1	0461 239 884	Arc welding cable	5 m
20	1	0460 504 880	Control box	PEK, see separate manual

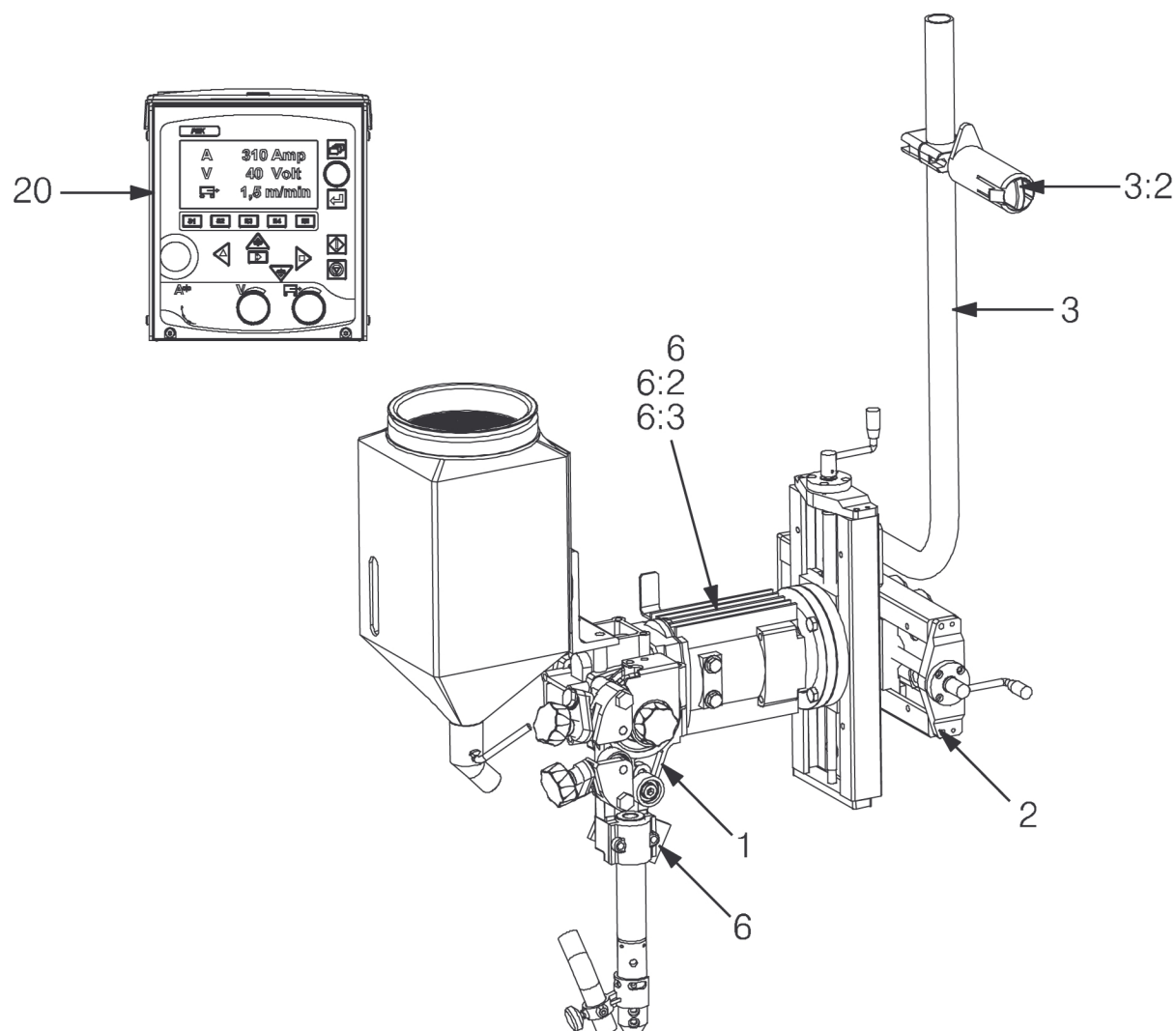

1.9 Welding head with PAV and PEK

Item no.	Qty	Ordering number	Denomination	Notes
		0449 270 911	Welding head with PAV and PEK	A6SF F1, SAW (74:1)
1	1	0449 250 890	Wire feed unit (right mounted)	74:1
2	1	0449 251 884	Slide travel kit, motorised	300 mm
3	1	0449 255 880	Bobbin holder complete	
3:2	1	0146 967 880	Brake hub	
6	1	0449 253 902	Cable set	L=5 m

1 SPARE PARTS

Item no.	Qty	Ordering number	Denomination	Notes
6:2	1	0460 907 881	Motor cable	5 m
6:3	1	0461 239 884	Arc welding cable	5 m
20	1	0460 504 880	Control box	PEK, see separate manual
25	1	0460 697 880	Joint tracking unit	A6 PAV, see separate manual
26	1	0461 215 880	Cable set	
26:5	2	0417 310 888	Motor cable	5 m

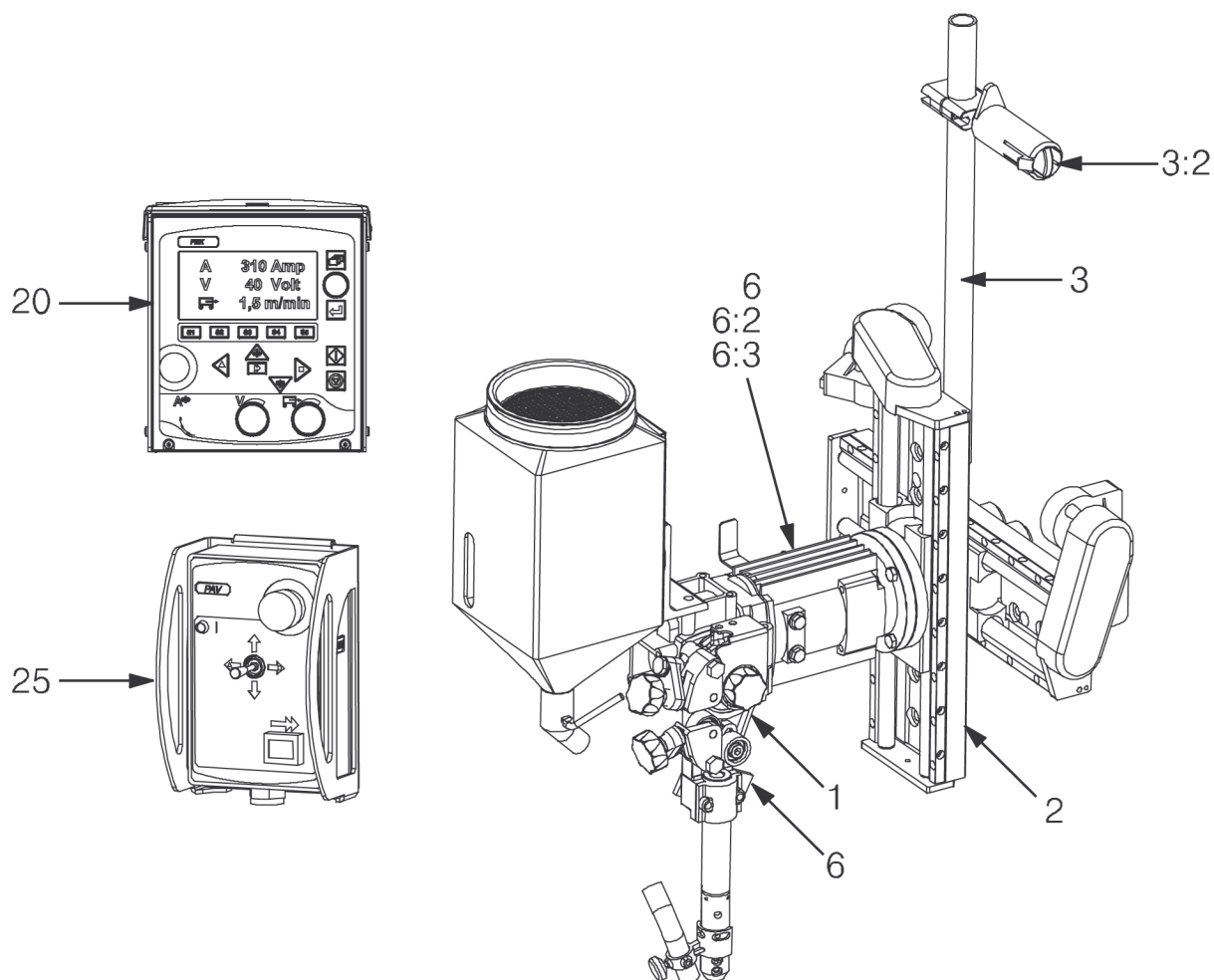

1.10 Welding head with GMH and PEK

Item no.	Qty	Ordering number	Denomination	Notes
		0449 270 912	Welding head with GMH and PEK	A6SF F1, SAW (74:1)
1	1	0449 250 890	Wire feed unit (right mounted)	74:1
2	1	0449 251 884	Slide travel kit, motorised	300 mm
3	1	0449 255 880	Bobbin holder complete	

1 SPARE PARTS

Item no.	Qty	Ordering number	Denomination	Notes
3:2	1	0146 967 880	Brake hub	
6	1	0449 253 902	Cable set	L=5 m
6:2	1	0460 907 881	Motor cable	5 m
6:3	1	0461 239 884	Arc welding cable	5 m
20	1	0460 504 880	Control box	PEK, see separate manual
25	1	0460 884 880	Joint tracking system	A6 GMH, see separate manual
26	1	0461 215 880	Cable set	
26:5	2	0417 310 888	Motor cable	5 m

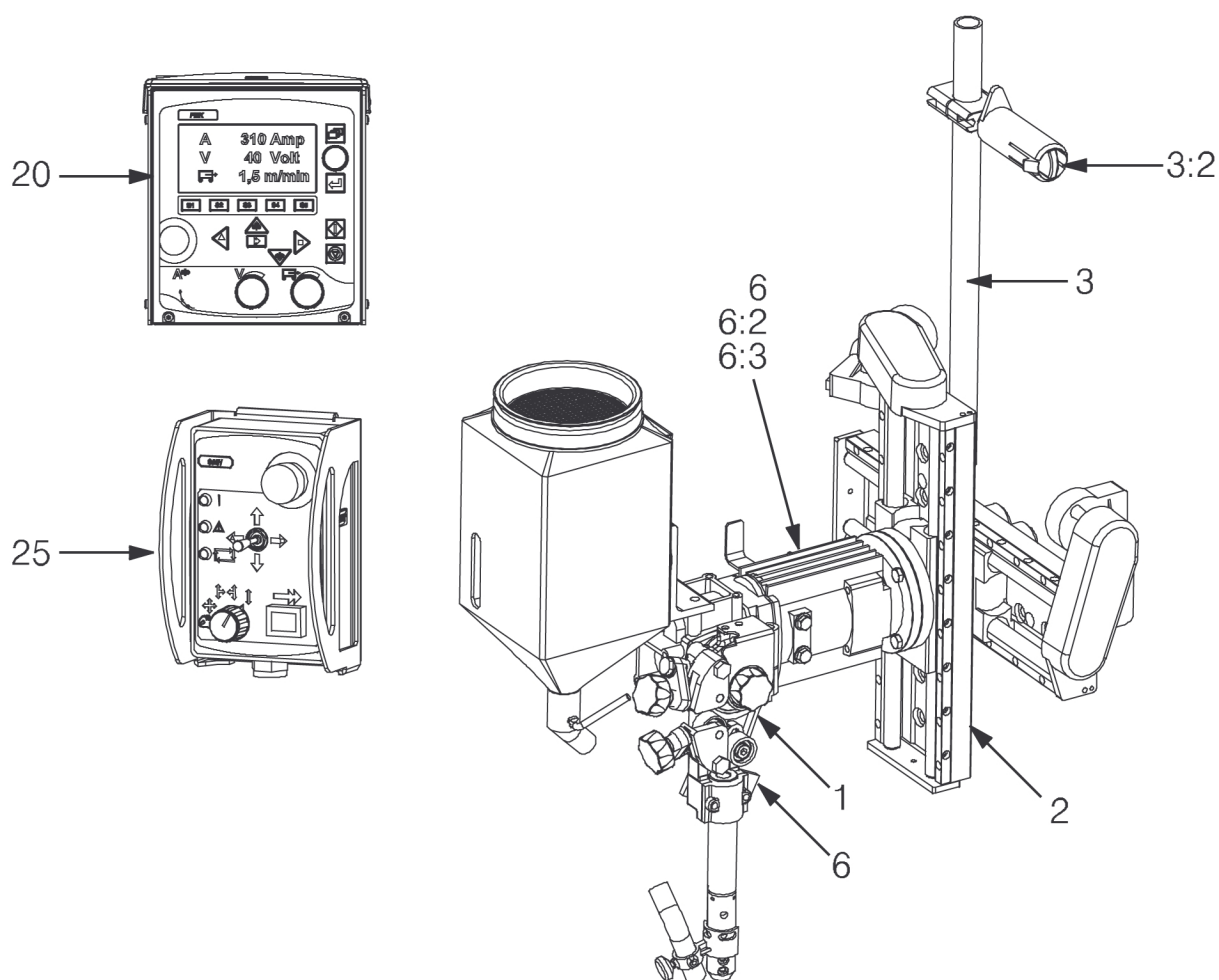

1.11 Welding head with PEK

Item no.	Qty	Ordering number	Denomination	Notes
		0449 270 913	Welding head with PEK	A6SF F1, SAW (74:1)
1	1	0449 250 890	Wire feed unit (right mounted)	74:1
2	1	0449 251 884	Slide travel kit, motorised	300 mm

1 SPARE PARTS

Item no.	Qty	Ordering number	Denomination	Notes
3	1	0449 255 880	Bobbin holder complete	
3:2	1	0146 967 880	Brake hub	
6	1	0449 253 902	Cable set	L=5 m
6:2	1	0460 907 881	Motor cable	5 m
6:3	1	0461 239 884	Arc welding cable	5 m
20	1	0460 504 880	Control box	PEK, see separate manual

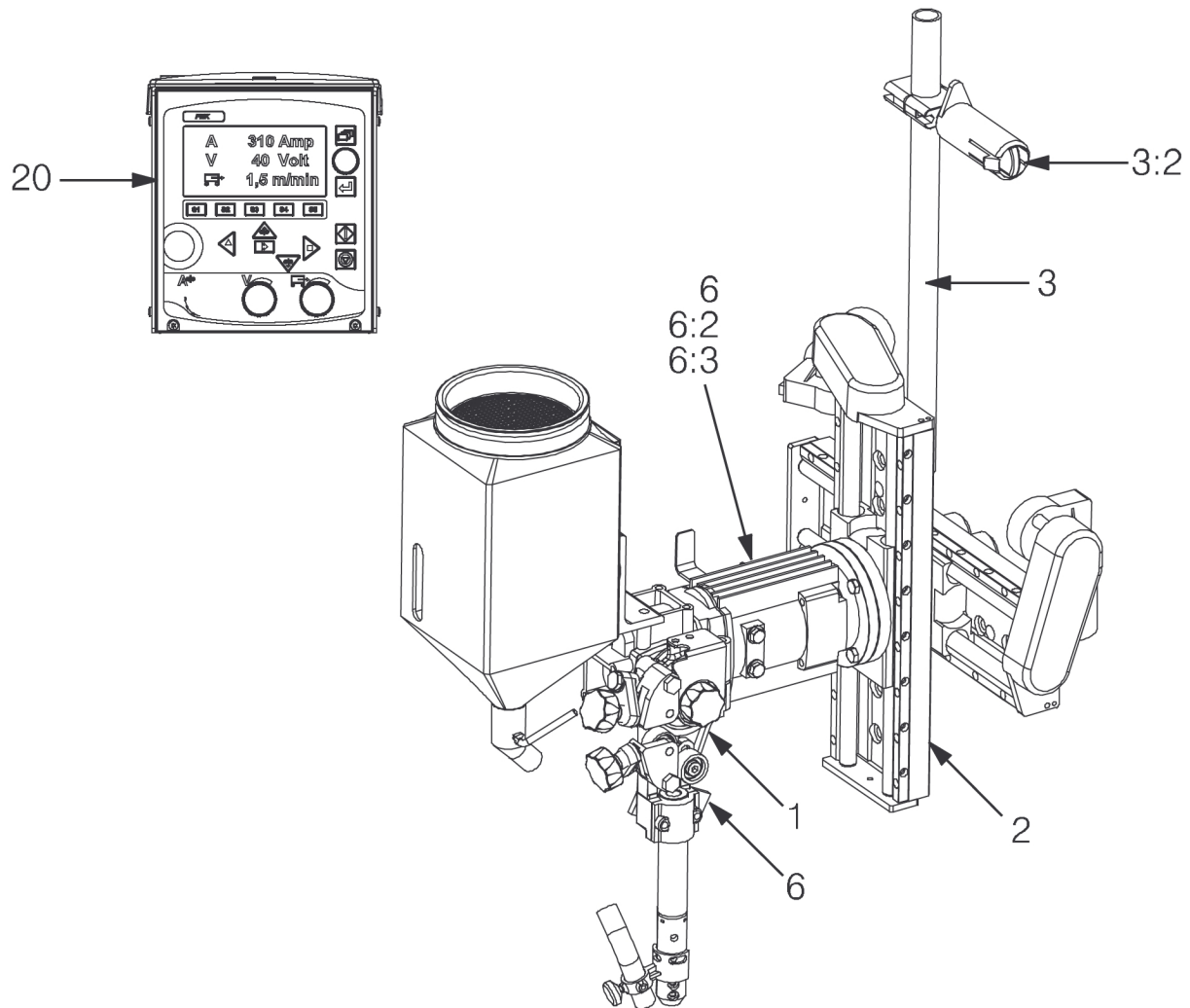

1.12 Welding head with PAV and PEK

Item no.	Qty	Ordering number	Denomination	Notes
		0449 270 914	Welding head with PAV and PEK	A6SF F1, SAW (74:1)
1	1	0449 250 892	Wire feed unit (Right mounted)	74:1
2	1	0449 251 885	Slide travel kit, motorised	300 mm
6	1	0449 253 902	Cable set	5 m
6:2	1	0460 907 881	Motor cable	5 m

Item no.	Qty	Ordering number	Denomination	Notes
6:3	1	0461 239 884	Arc welding cable	5 m
20	1	0460 504 880	Control box	PEK, see separate manual
25	1	0460 697 880	Joint tracking system	A6 PAV, see separate manual
26	1	0461 215 880	Cable set	

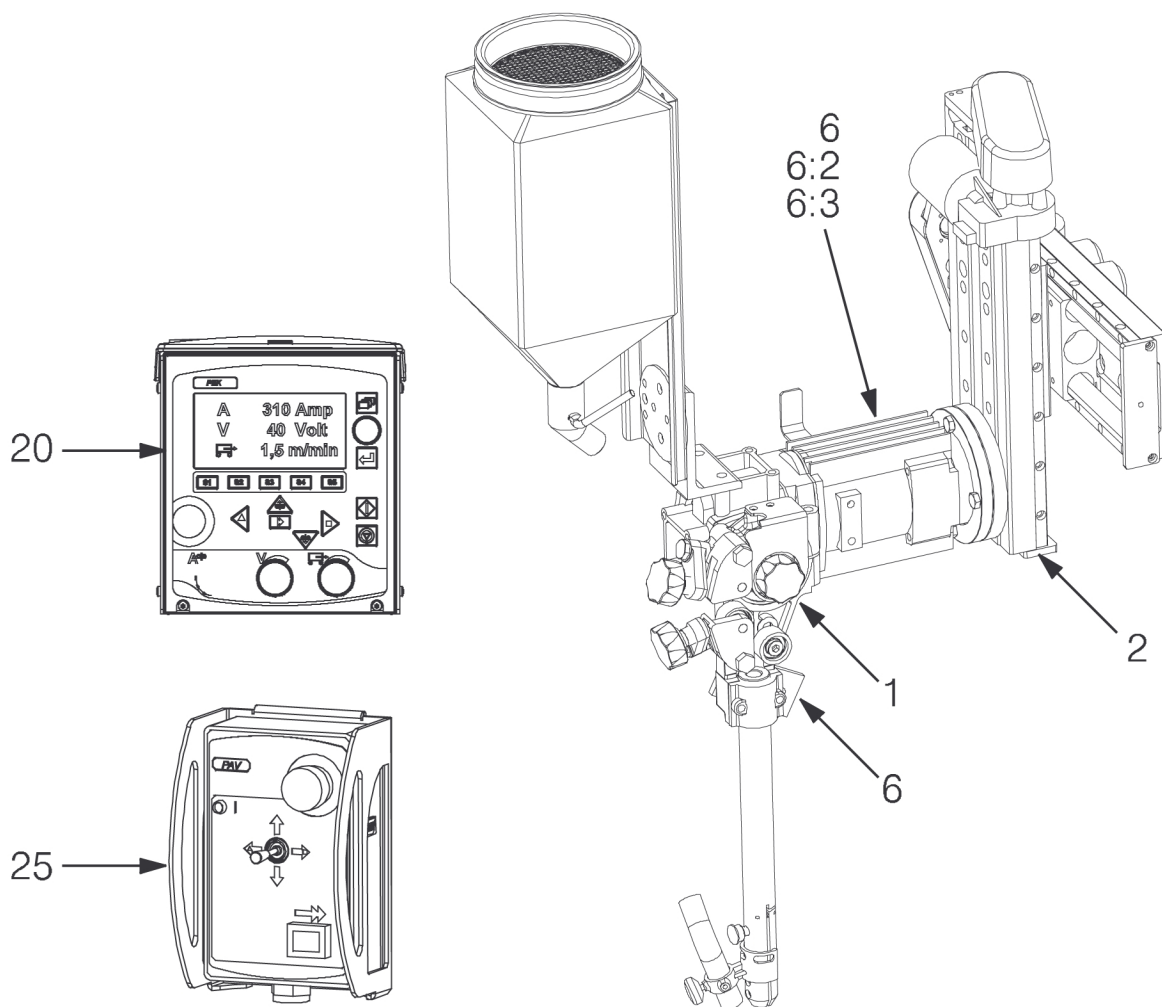

1.13 Welding head with GMH and PEK

Item no.	Qty	Ordering number	Denomination	Notes
		0449 270 915	Welding head with GMH and PEK	A6SF, SAW (74:1)
1	1	0449 250 892	Wire feed unit (right mounted)	74:1
2	1	0449 251 885	Slide travel kit, motorised	300 mm
6	1	0449 253 902	Cable set	5 m
6:2	1	0460 907 881	Motor cable	5 m
6:3	1	0461 239 884	Arc welding cable	5 m

1 SPARE PARTS

Item no.	Qty	Ordering number	Denomination	Notes
20	1	0460 504 880	Control box	PEK, see separate manual
25	1	0460 884 880	Joint tracking system	A6 GMH, see separate manual
26	1	0461 215 880	Cable set	

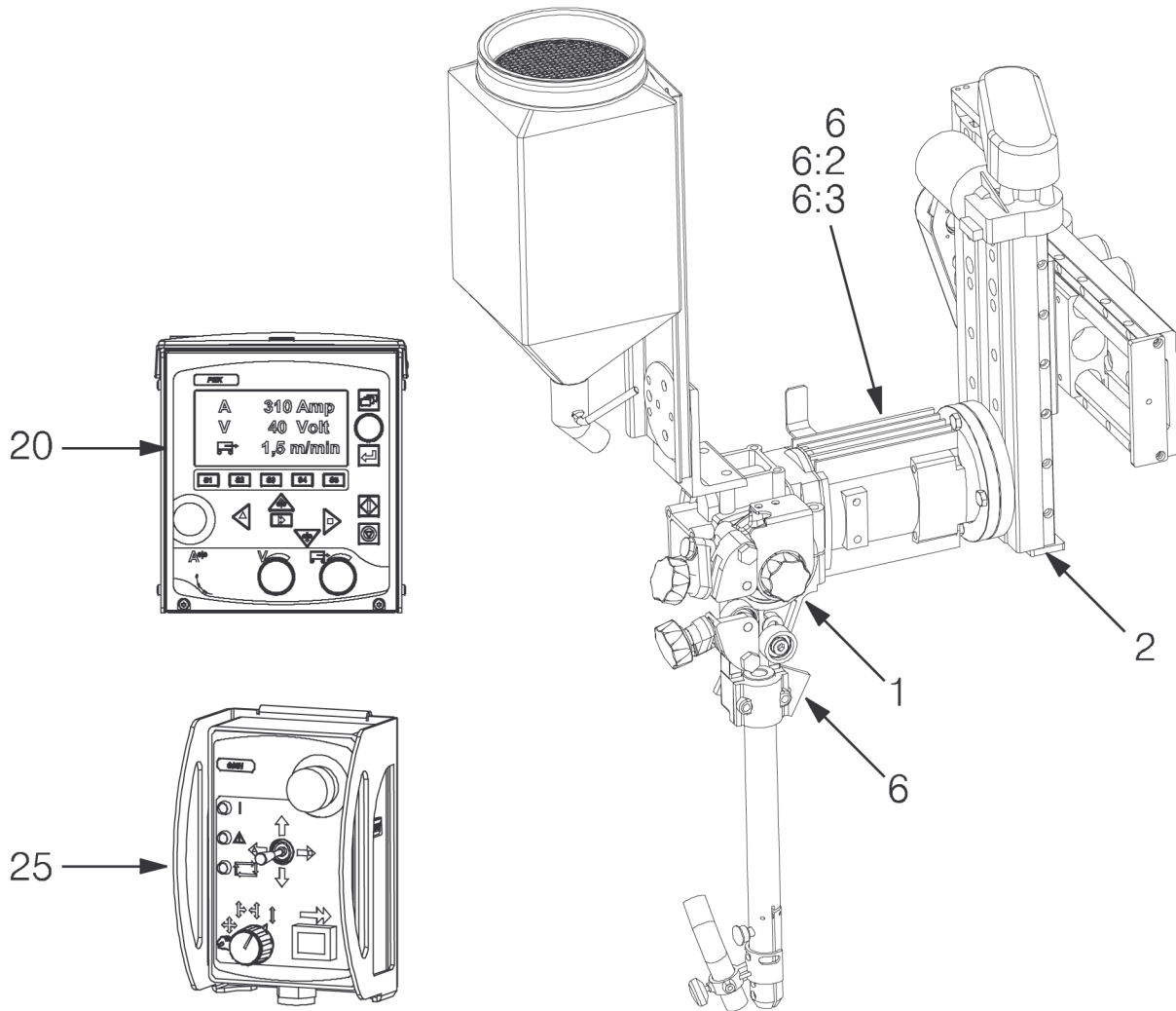

1.14 Welding head with PEK

Item no.	Qty	Ordering number	Denomination	Notes
		0449 270 916	Welding head with PEK	A6SF F1, SAW (74:1)
1	1	0449 250 892	Wire feed unit (right mounted)	74:1
2	1	0449 251 885	Slide travel kit, motorised	300 mm
6	1	0449 253 902	Cable set	5 m
6:2	1	0460 907 881	Motor cable	5 m
6:3	1	0461 239 884	Arc welding cable	5 m
20	1	0460 504 880	Control box	PEK, see separate manual

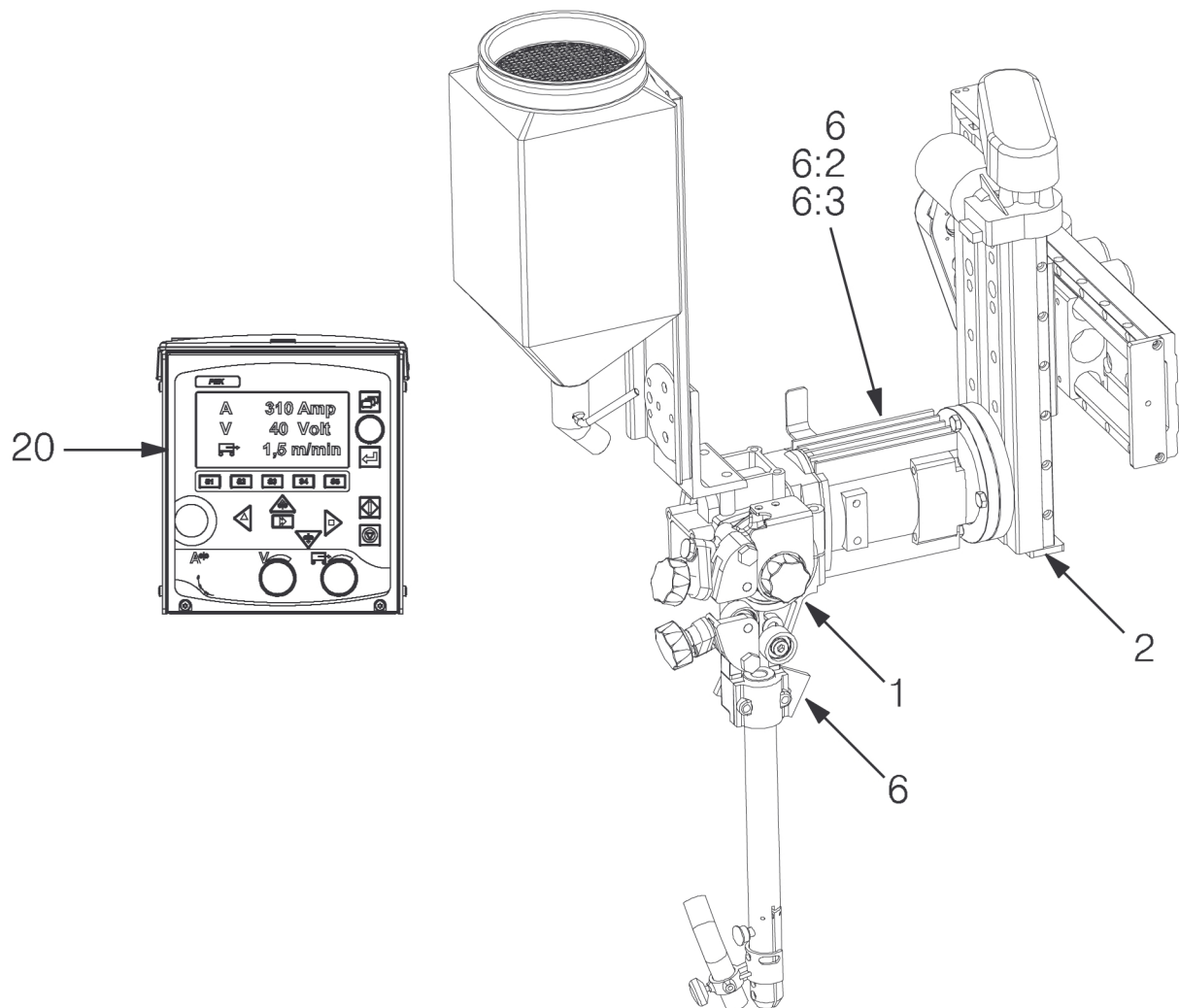

1.15 Welding head without control unit

Item no.	Qty	Ordering number	Denomination	Notes
		0449 270 950	Welding head without control unit	A6SF F1, SAW (115:1)
1	1	0912 360 881	Wire feed unit (right mounted)	SAW 115:1
2	1	0449 251 885	Slide travel kit, motorised	300 mm

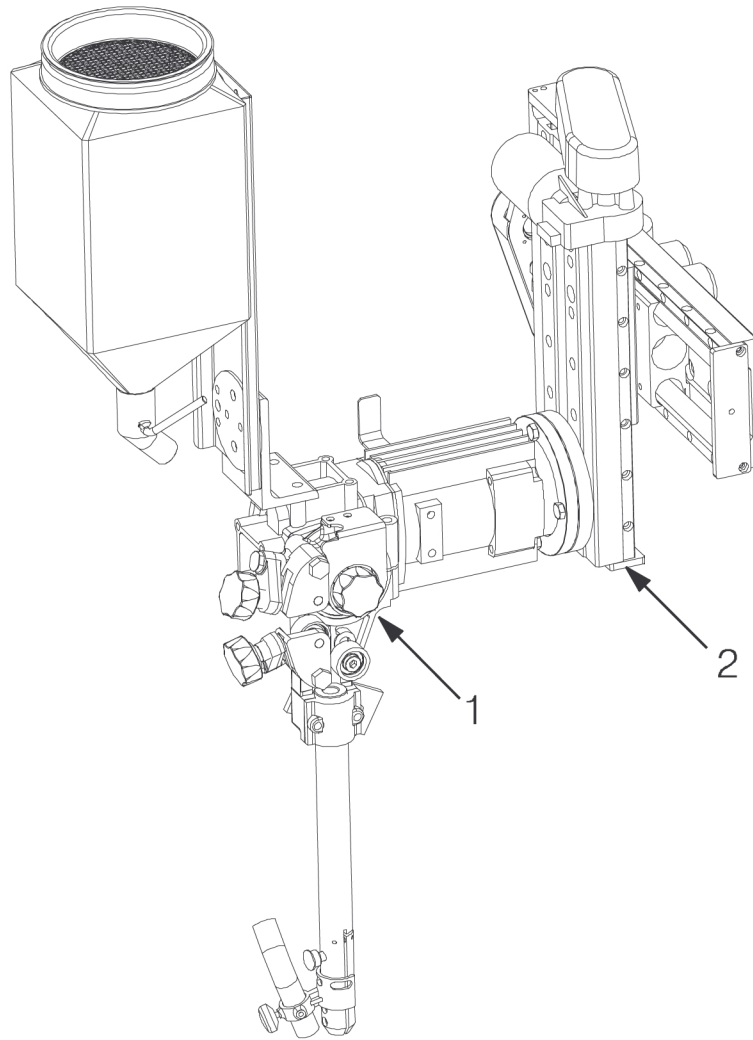

1.16 Wire feed unit (Right mounted)

Item no.	Qty	Ordering number	Denomination	Notes
		0449 250 880	Wire feed unit (Right mounted)	SAW (156:1), Single
1	1	0145 063 906	Motor with gear	A6 VEC (156:1), see separate manual
2	1	0147 639 880	Wire straightener (right mounted)	D35
3	1	0218 810 183	Insulated hand wheel	
4	1	0334 290 882	Contact equipment	D35/L275
6	1	0148 487 880	Bracket for flux hopper	
7	1	0147 649 881	Flux hopper	10 L
10	1	0457 713 001	Bar	
20	1	0449 498 880	Junction box complete	
22	1	0334 294 001	Attachment	
29	1	0449 528 001	Protection plate	

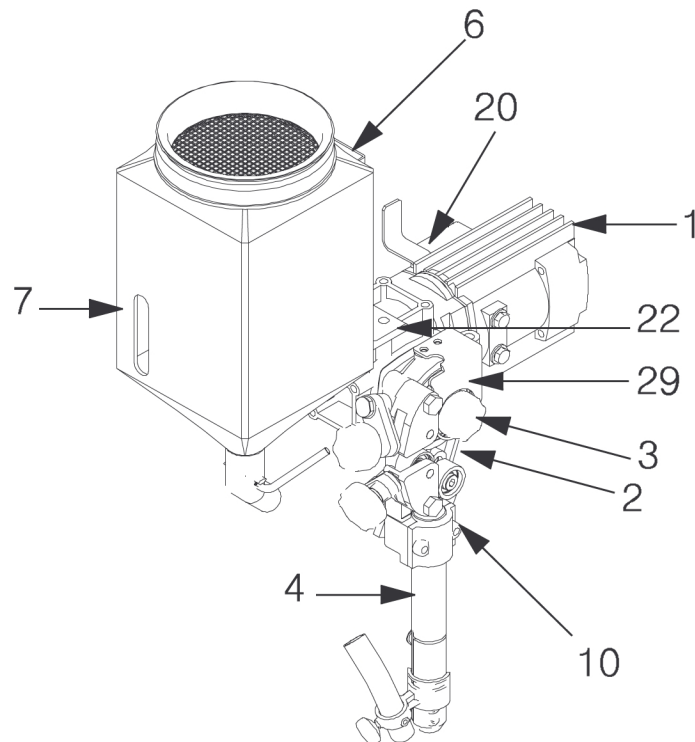

1.17 Wire feed unit

Item no.	Qty	Ordering number	Denomination	Notes
		0449 250 882	Wire feed unit	SAW (156:1) CaB
1	1	0145 063 906	Motor with gear	A6 VEC (156:1), see separate manual
2	1	0147 639 880	Wire straightener (right mounted)	D35
3	1	0218 810 183	Insulated hand wheel	
4	1	0334 290 884	Contact equipment single wire	D35/L400
6	1	0148 487 881	Bracket for flux hopper	
7	1	0147 649 882	Flux hopper	10 L
10	1	0457 713 001	Bar	
20	1	0449 498 880	Junction box complete	
22	1	0334 294 001	Attachment	
29	1	0449 528 001	Protection right	

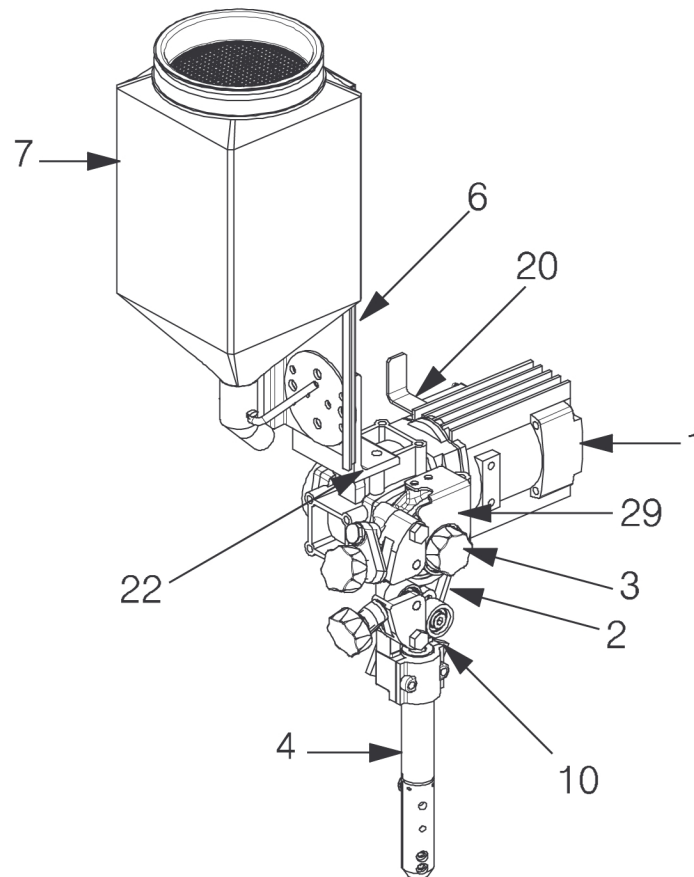

1.18 Wire feed unit

Item no.	Qty	Ordering number	Denomination	Notes
		0449 250 883	Wire feed unit	SAW (156:1) CaB
1	1	0145 063 906	Motor with gear	A6 VEC (156:1), see separate manual
2	1	0147 639 880	Wire straightener (right mounted)	D35
3	1	0218 810 183	Insulated hand wheel	
4	1	0334 290 884	Contact equipment single wire	D35/L400
6	1	0148 487 881	Bracket for flux hopper	
7	1	0147 649 882	Flux hopper	10 L
10	1	0457 713 001	Bar	
20	1	0449 498 880	Junction box complete	
22	1	0334 294 001	Attachment	
29	1	0449 528 001	Protection plate	
30	1	0155 300 001	Plate	
32	2	0156 800 002	Wire liner	D8/4

1 SPARE PARTS

Item no.	Qty	Ordering number	Denomination	Notes
35*	1	0146 967 880	Brake hub	
36*	2	0154 734 001	Brake hub clamp	

* Not shown in the picture

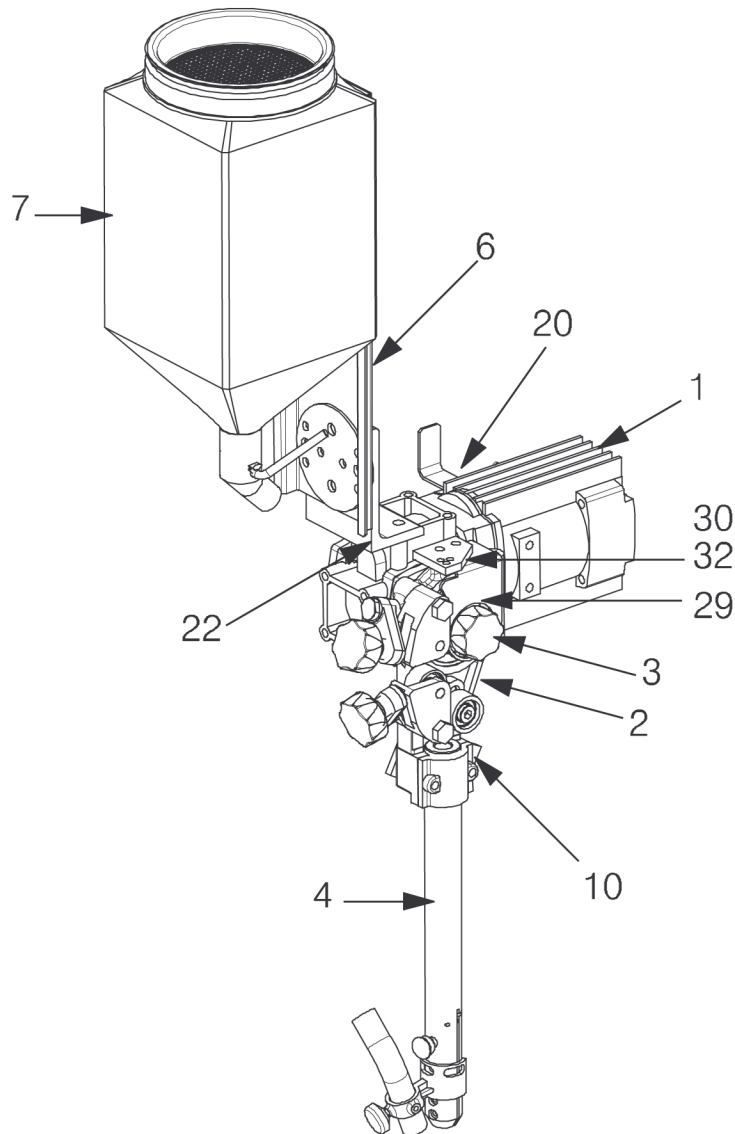

1.19 Wire feed unit (Right mounted)

Item no.	Qty	Ordering number	Denomination	Notes
		0449 250 890	Wire feed unit (Right mounted)	SAW (74:1), Single
1	1	0145 063 907	Motor with gear	A6 VEC (74:1), see separate manual
2	1	0147 639 880	Wire straightener (right mounted)	D35
3	1	0218 810 183	Insulated hand wheel	
4	1	0334 290 882	Contact equipment	D35/ L275

1 SPARE PARTS

Item no.	Qty	Ordering number	Denomination	Notes
6	1	0148 487 880	Bracket for flux hopper	
7	1	0147 649 881	Flux hopper	10 L
10	1	0457 713 001	Bar	
20	1	0449 498 880	Junction box complete	
22	1	0334 294 001	Attachment	
29	1	0449 528 001	Protection plate	

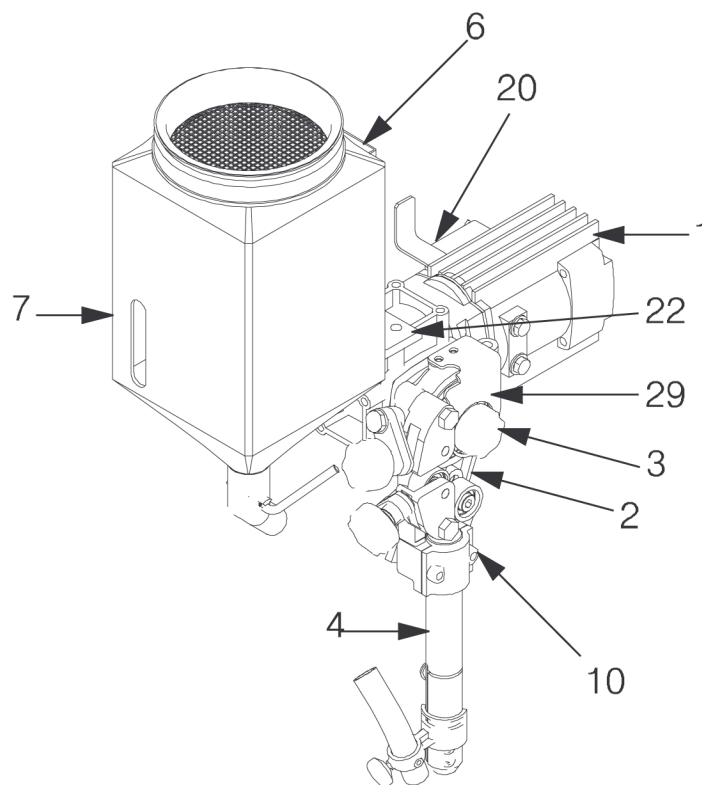

1.20 Wire feed unit (Right mounted)

Item no.	Qty	Ordering number	Denomination	Notes
		0449 250 892	Wire feed unit (Right mounted)	SAW (74:1), Single
1	1	0145 063 907	Motor with gear	A6 VEC (74:1), see separate manual
2	1	0147 639 880	Wire straightener (right mounted)	D35
3	1	0218 810 183	Insulated hand wheel	
4	1	0334 290 884	Contact equipment	D35/ L275

1 SPARE PARTS

Item no.	Qty	Ordering number	Denomination	Notes
6	1	0148 487 881	Bracket for flux hopper	
7	1	0147 649 882	Flux hopper	10 L
10	1	0457 713 001	Bar	
20	1	0449 498 880	Junction box complete	
22	1	0334 294 001	Attachment	
29	1	0449 528 001	Protection right	

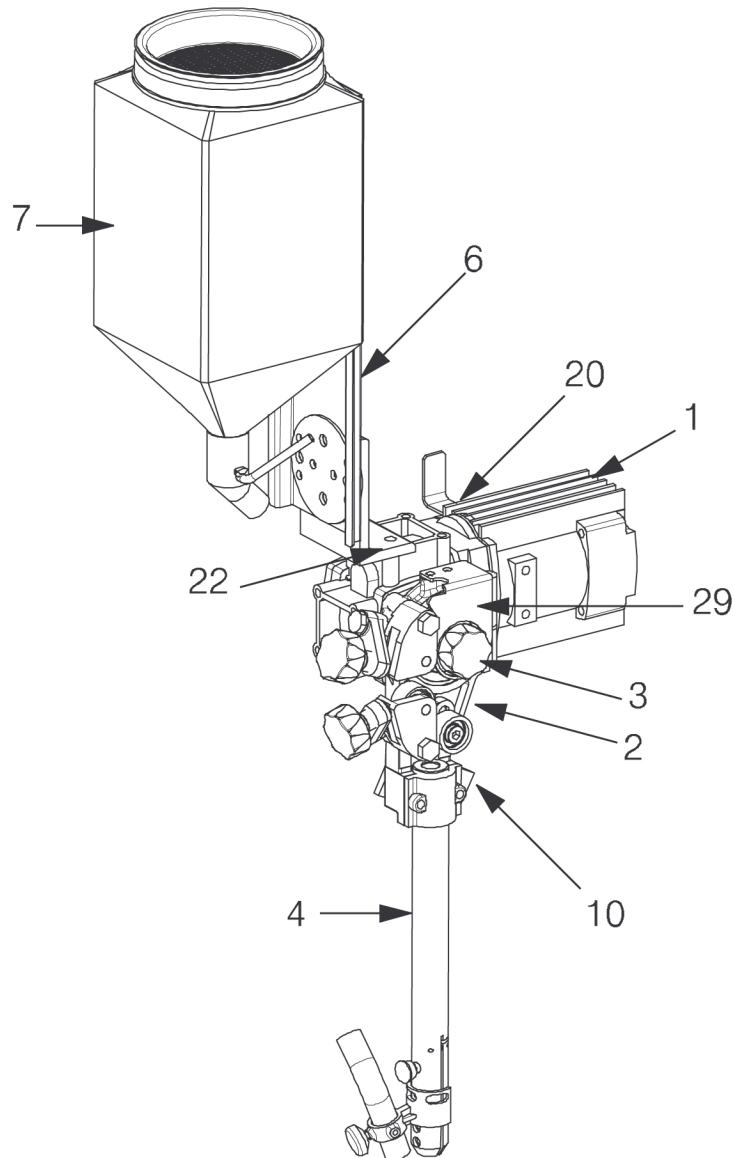

1.21 Wire straightener (right mounted)

Item no.	Qty	Ordering number	Denomination	Notes
		0147 639 880	Wire straightener (right mounted)	
1	1	0156 449 001	Clamp	

1 SPARE PARTS

Item no.	Qty	Ordering number	Denomination	Notes
4	1	0215 503 601	Insulating sleeve	
5	1	0156 530 001	Clamp half	D35
6	2	0212 900 001	Spacer screw	
7	4	0215 201 209	Sealing, O-ring	D11.3×2.4
8	2	0218 400 801	Pressure roller arm	
9	1	0218 810 181	Handwheel, insulated	
10	1	0218 810 182	Handwheel, insulated	
11	3	0332 408 001	Stub shaft	
13	3	0153 148 880	Pressure roller	
14	1	0415 498 001	Pressure roller, upper	
15	2	0212 902 601	Spacer screw	
16	1	0415 499 001	Pressure roller, lower	
19	2	0219 501 013	Spring washer	D18.1/10.2
28	1	0156 531 001	Clamp half	D35
30	1	0212 601 110	Nut	M10

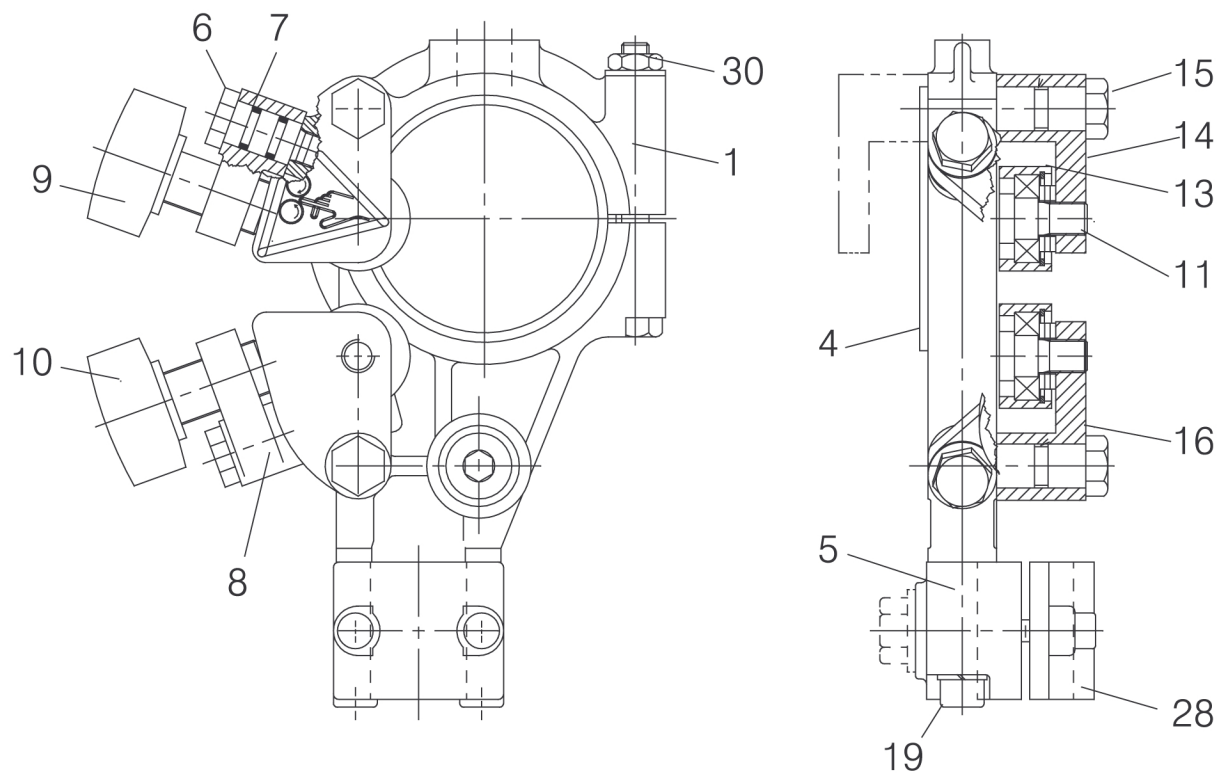

1.22 Contact equipment single wire

Item no.	Qty	Ordering number	Denomination	Notes
		0334 290 882	Contact equipment single wire	D35
2	1	0417 959 881	Contact jaw tube	L=275
11	1	0153 299 880	Flux nozzle complete	

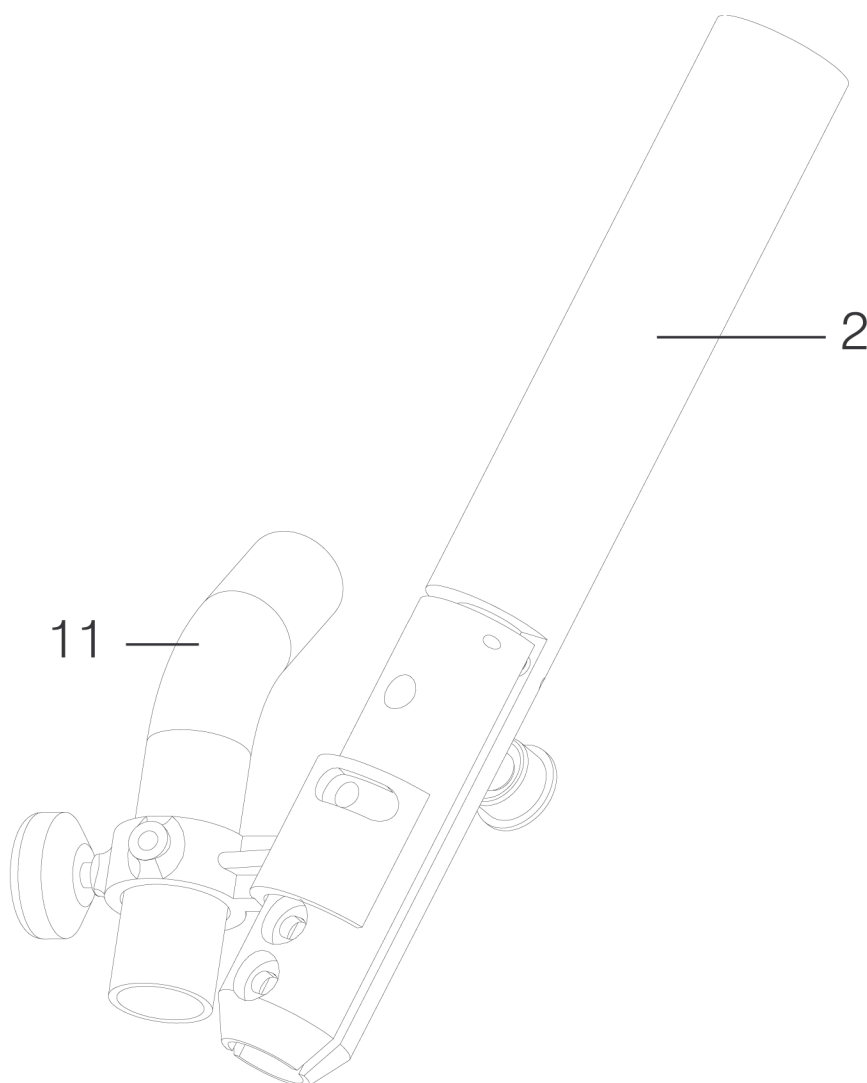

1.23 Contact equipment single wire

Item no.	Qty	Ordering number	Denomination	Notes
		0334 290 884	Contact equipment single wire	D35
1	1	0417 959 882	Contact jaw tube	L=400
3	1	0265 900 880	Contact jaw	Ø 3, L=58 mm
4	1	0265 900 882	Contact jaw	Ø 4, L=58 mm

1 SPARE PARTS

Item no.	Qty	Ordering number	Denomination	Notes
5	1	0265 900 883	Contact jaw	Ø 5, L=58 mm
6	1	0265 900 884	Contact jaw	Ø 6
7	1	0218 510 298	Feed roller	Ø 3
8	1	0218 510 286	Feed roller	Ø 4
9	1	0218 510 287	Feed roller	Ø 5
10	1	0218 510 288	Feed roller	Ø 6
11	1	0153 299 880	Flux nozzle complete	

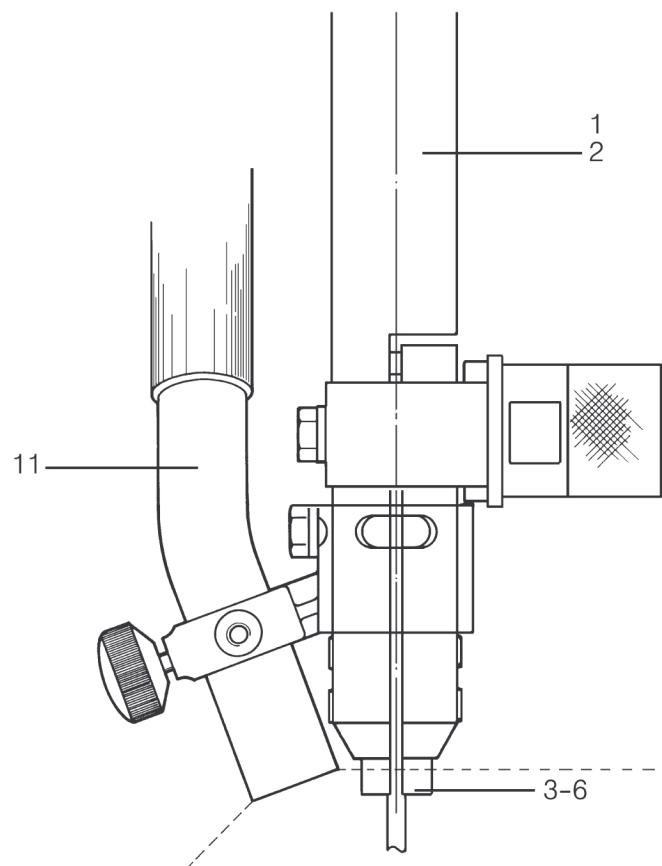

1.24 Contact jaw tube

Item no.	Qty	Ordering number	Denomination	Notes
		0417 959 881	Contact jaw tube	L=275 mm
4	1	0443 372 001	Fitting bolt	
5	4	0219 504 307	Cup spring	D20/10.2, T=1.1
6	1	0417 979 001	Ring	
8	1	0443 344 881	Contact tube	L=275 mm

1 SPARE PARTS

Item no.	Qty	Ordering number	Denomination	Notes
		0417 959 882	Contact jaw tube	L=400 mm
4	1	0443 372 001	Fitting bolt	
5	4	0219 504 307	Cup spring	D20/10.2, T=1.1
6	1	0417 979 001	Ring	
9	1	0443 344 882	Contact tube	L=400 mm

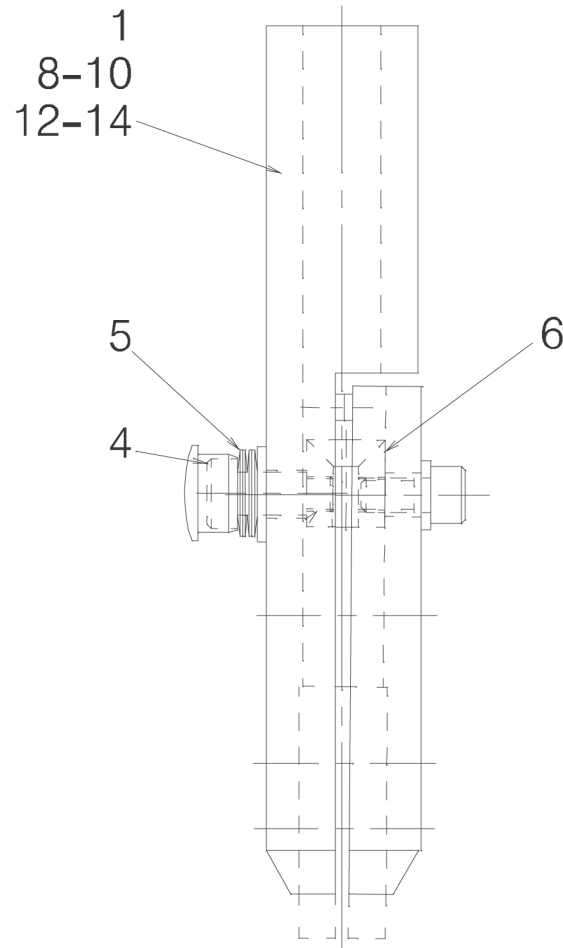

1.25 Flux nozzle complete

Item no.	Qty	Ordering number	Denomination	Notes
		0153 299 880	Flux nozzle complete	
1	1	0153 290 002	Holder for flux pipe	
2	1	0153 296 001	Flux pipe, bent	
3	1	0153 425 001	Wheel	

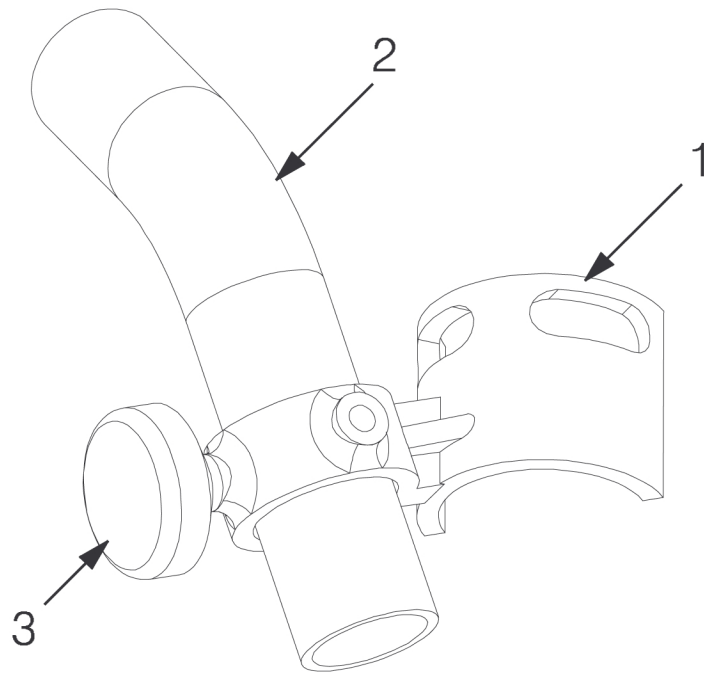

1.26 Flux hopper

Item no.	Qty	Ordering number	Denomination	Notes
		0147 649 881	Flux hopper	10 L
1	1	0154 007 001	Flux hopper	
2	1	0148 837 001	Window (A6 flux hopper)	
3	1	0147 645 001	Mounting	
6	1	0153 347 880	Flux valve	
7	1	0215 201 232	Sealing, O-ring	69.2×5.7
13	1	0020 301 780	Flux strainer	
14	1	0443 383 002	Flux hose	L=500

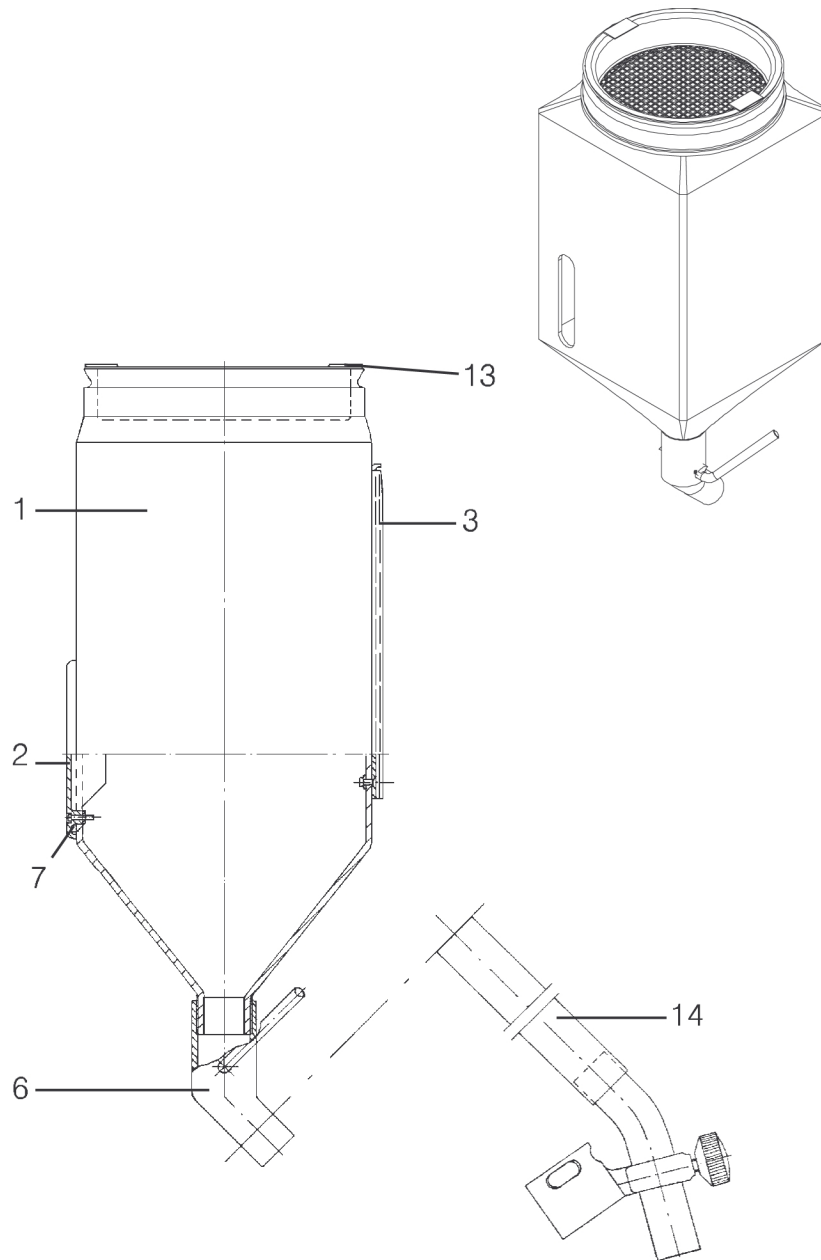

1.27 Flux hopper

Item no.	Qty	Ordering number	Denomination	Notes
		0147 649 882	Flux hopper	10 L
1	1	0154 007 002	Flux hopper	
3	1	0147 645 001	Mounting	
6	1	0153 347 880	Flux valve	
13	1	0020 301 780	Flux strainer	
14	1	0443 383 002	Flux hose	L=500

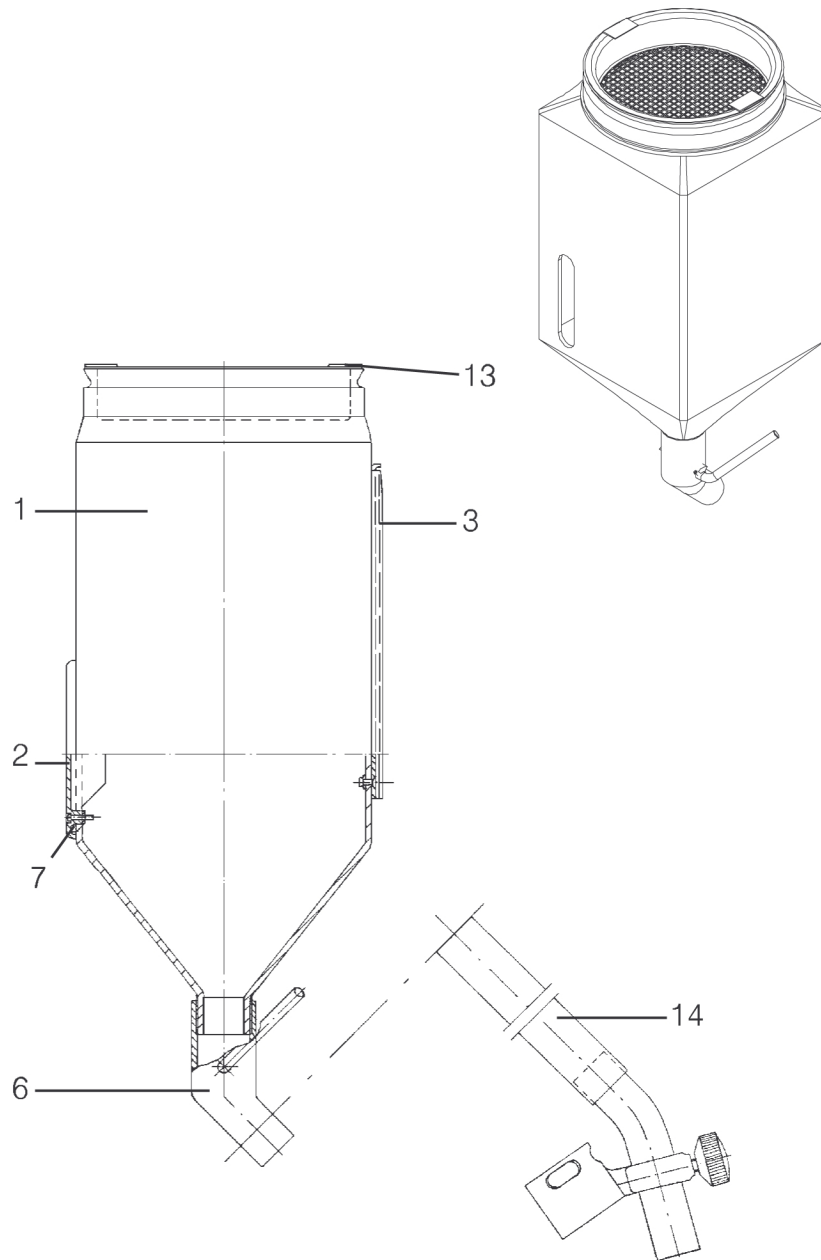

1.28 Flux valve

Item no.	Qty	Ordering number	Denomination	Notes
		0153 347 880	Flux valve	
1	1	0153 348 001	Outlet	
2	1	0153 349 001	Shaft	
3	1	0211 102 938	Roll pin	D3×20

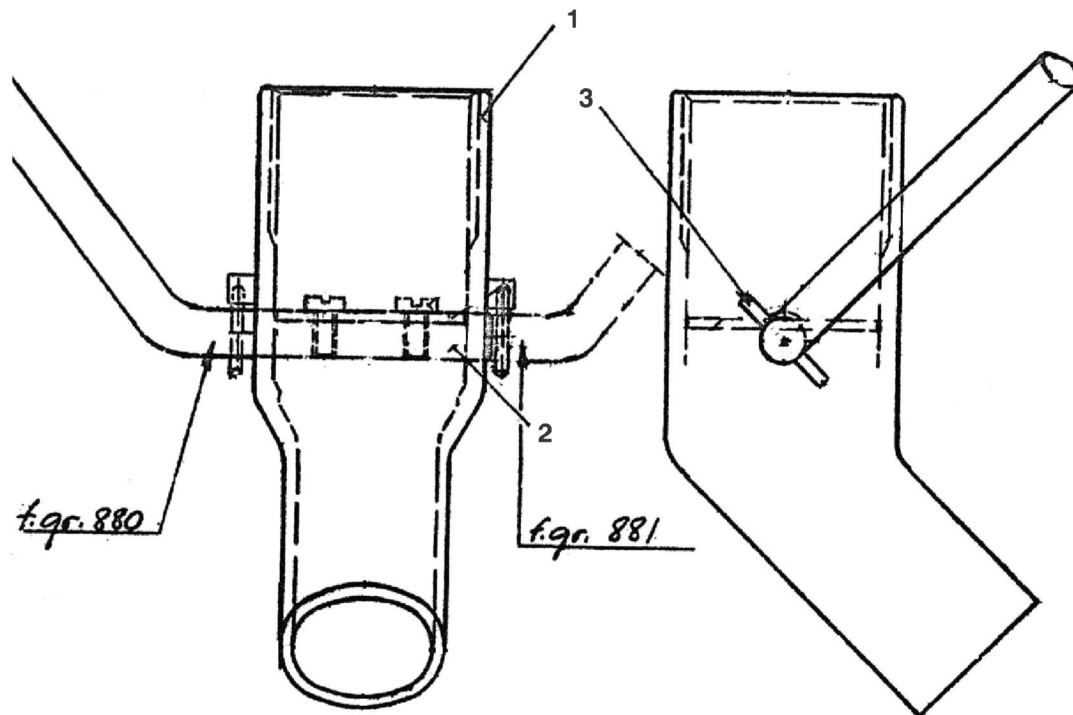

1.29 Guide tube insert for fine wire

Item no.	Qty	Ordering number	Denomination	Notes
		0334 278 881	Guide tube insert for fine wire	
2	1	0218 518 201	Clamp	
3	2	0415 032 001	Guide tube	L=358 mm

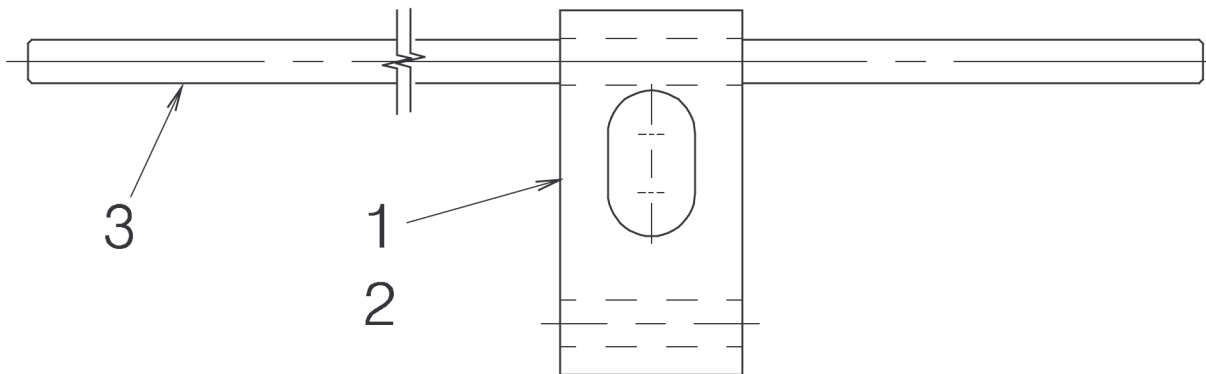

1.30 Slide travel kit motorised

Item no.	Qty	Ordering number	Denomination	Notes
		0449 251 884	Slide travel kit motorised	300 mm
1	2	0334 333 884	Motorised slide	li=300
30	1	0449 251 999	Common parts motorised slide	
		0449 251 885	Slide travel kit motorised	300 mm
1	2	0334 333 884	Motorised slide	li=300
30	1	0449 251 999	Common parts motorised slide	
		0449 251 999	Common parts motorised slide	A6
2	1	0334 171 001	Plate	
4	1	0334 170 001	Clamping ring	
5	1	0334 172 001	Gear bracket	
10	4	0278 300 180	Insulator	

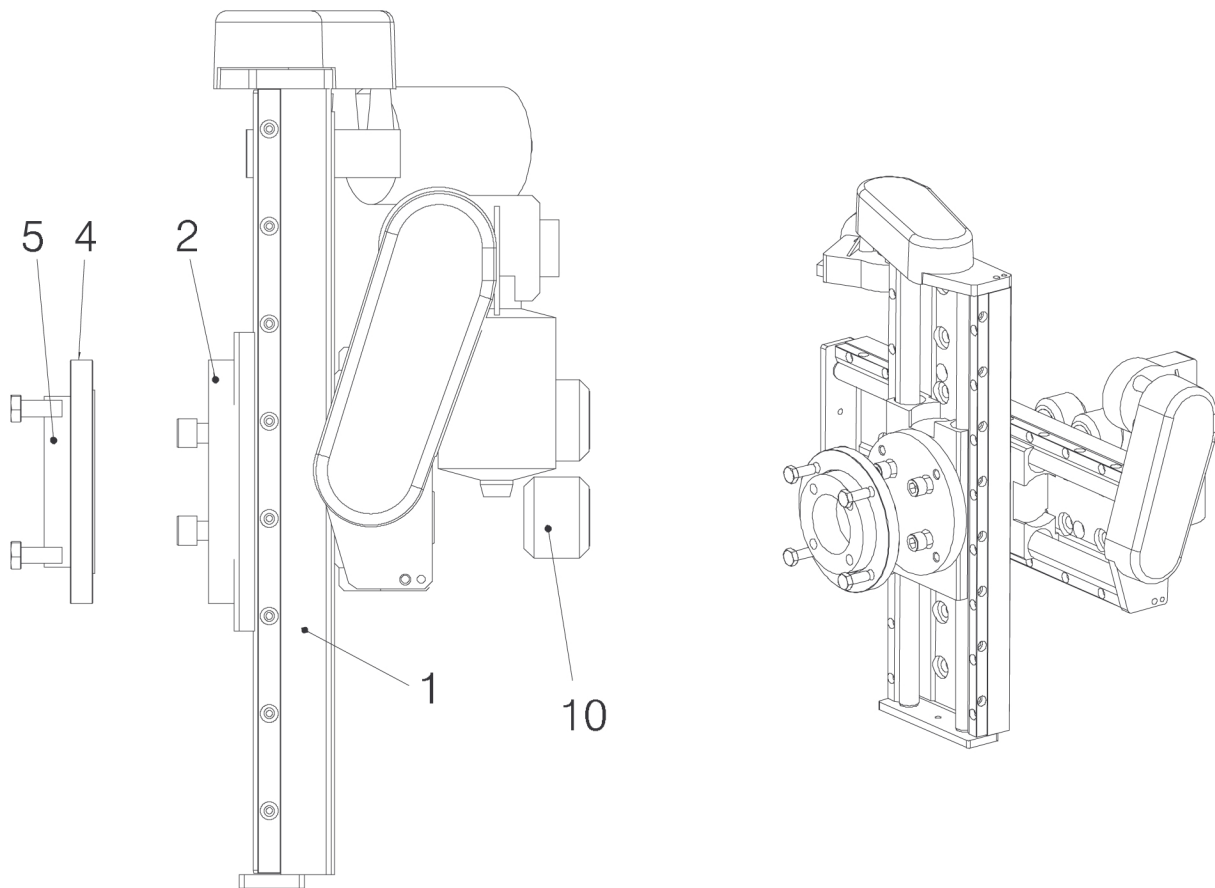

1.31 Slide travel kit, manual

Item no.	Qty	Ordering number	Denomination	Notes
		0449 252 881	Slide travel kit, manual	210 mm
1	2	0154 465 881	Slide manual	L=210
2	1	0334 171 001	Plate	
4	1	0334 170 001	Clamping ring	
5	1	0334 172 001	Gear bracket	
10	4	0278 300 180	Insulator	2000 V

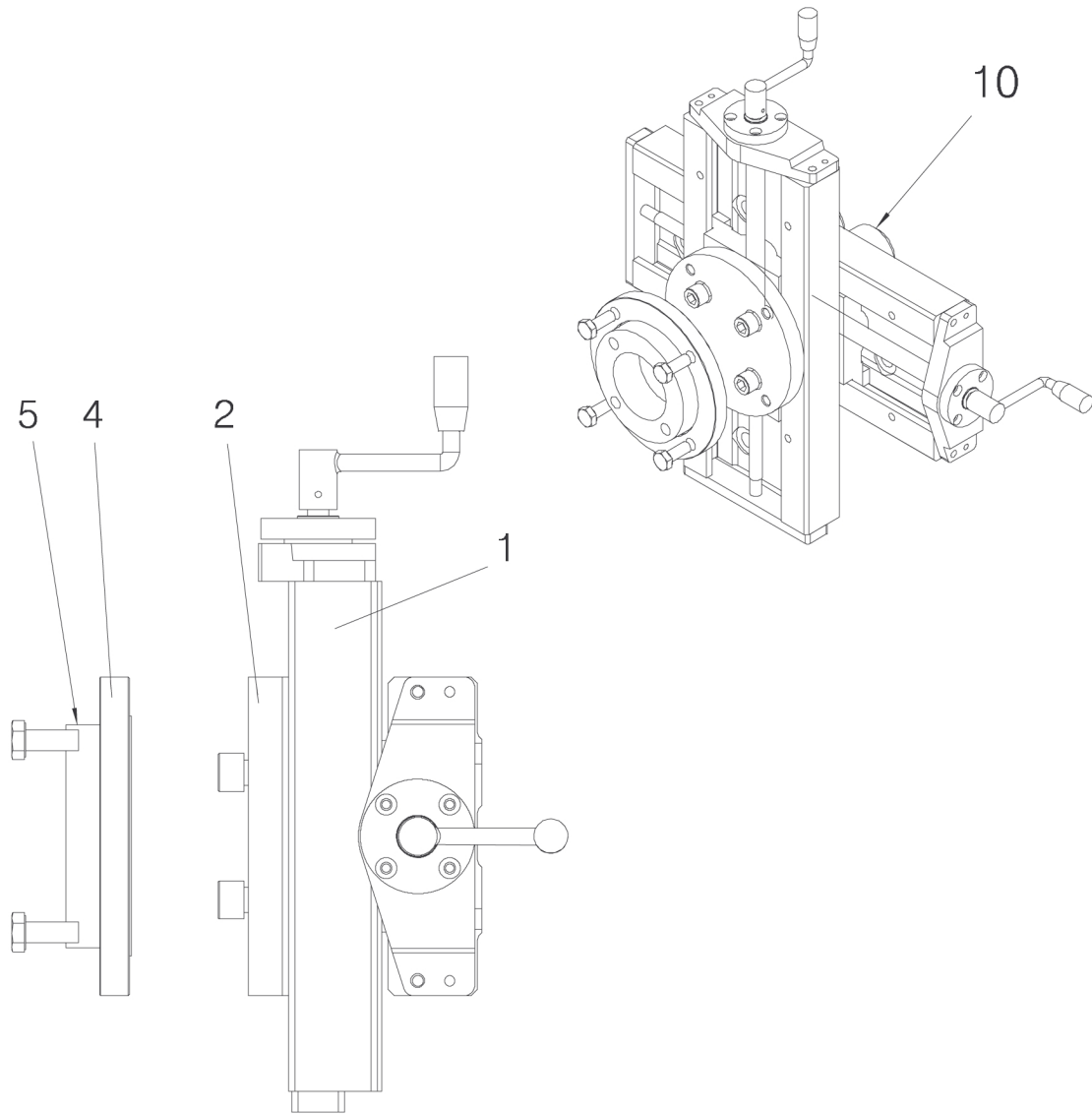

1.32 Slide, manually operated

Item no.	Qty	Ordering number	Denomination	Notes
		0154 465 881	Slide, manually operated	
2	1	0154 464 002	Slide frame	
6	1	0154 463 880	Carriage with slide rails	
7	6	0190 509 485	Stop screw	M10×10
8	1	0154 458 001	End piece	
10	2	0211 102 957	Roll pin	D5×20
12	1	0154 461 002	Lead screw	
16	1	0190 531 201	Ball bearing	SKF 3201
17	1	0154 456 001	Lock nut	
18	1	0154 457 001	Ball bearing cap	
22	1	0334 537 001	Handle crank	
23	1	0211 102 938	Roll pin	D3×20

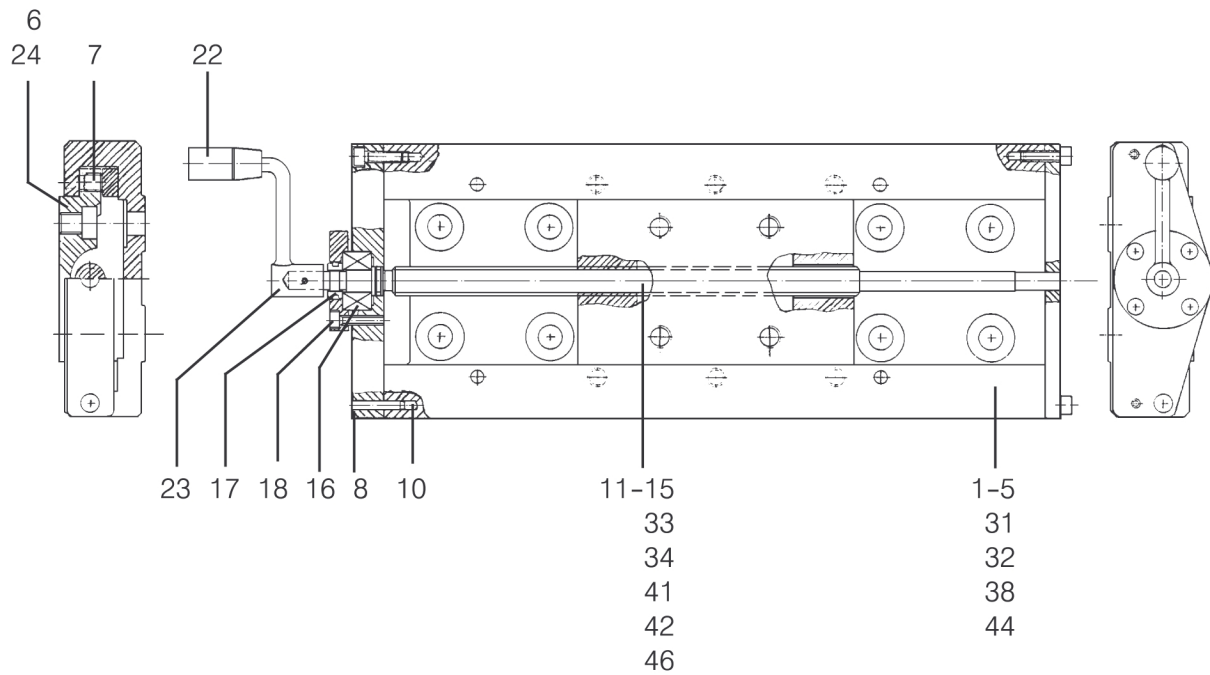

1.33 Bobbin holder complete

Item no.	Qty	Ordering number	Denomination	Notes
		0449 255 880	Bobbin holder complete	
1	1	0334 318 880	Bobbin holder straight	
2	1	0146 967 880	Brake hub	

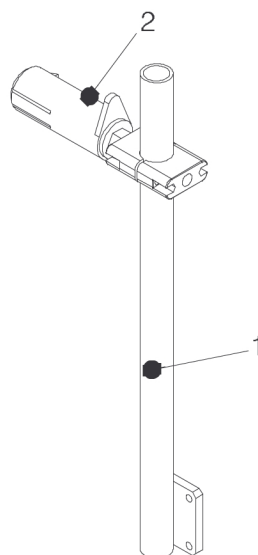

1.34 Bobbin holder complete

Item no.	Qty	Ordering number	Denomination	Notes
		0449 255 881	Bobbin holder complete	
1	1	0443 510 880	Bobbin holder bent	
2	1	0146 967 880	Brake hub	

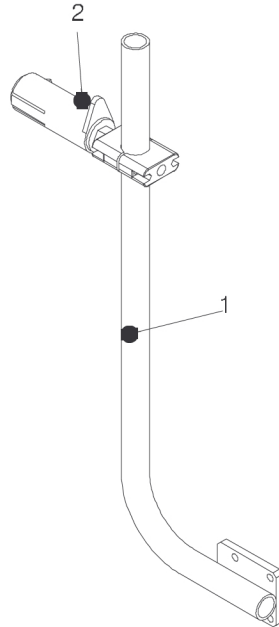



A WORLD OF PRODUCTS AND SOLUTIONS.



For contact information visit esab.com

ESAB AB, Lindholmsallén 9, Box 8004, 402 77 Gothenburg, Sweden, Phone +46 (0) 31 50 90 00

manuals.esab.com

